

Modular structure of a swivel foot

Application:

Swivel feet are of modular design. The components can be individually combined to match the application. The swivel feet are applicable for use on machines, plants and even office furniture.

Modular design:

Swivel feet consist of two components - a plate and a threaded spindle or ball joint.

Any plate can be combined with **any** threaded spindle or ball joint (see Figure 1).

Assembly:

Using a plastic hammer, knock the ball of the threaded spindle or ball joint vertically into the swivel foot plate. If necessary, the two fastening holes (closed) in the swivel foot plate can be opened by simply punching them out to allow the swivel foot to be fastened to a base.

Height of swivel foot:

Swivel feet always have a minimum height of $H = 22.5$ mm independently of the plate, threaded spindle or ball joint size (see Figure 2). When assembling with threaded spindle, the height of the complete swivel foot is calculated by adding 22.5 mm to the length of the threaded spindle + the height of the hexagon. (Total height of swivel foot = $L + L1 + 22.5$ mm).

When assembling with ball joint, the length L is void.

Note for ordering:

If the swivel foot plate and the threaded spindle or ball joint are to be supplied assembled, please add the suffix **"assembled"** to the order number for the plate and the spindle or ball joint (see sample order on the relevant product page).

Fig. 1

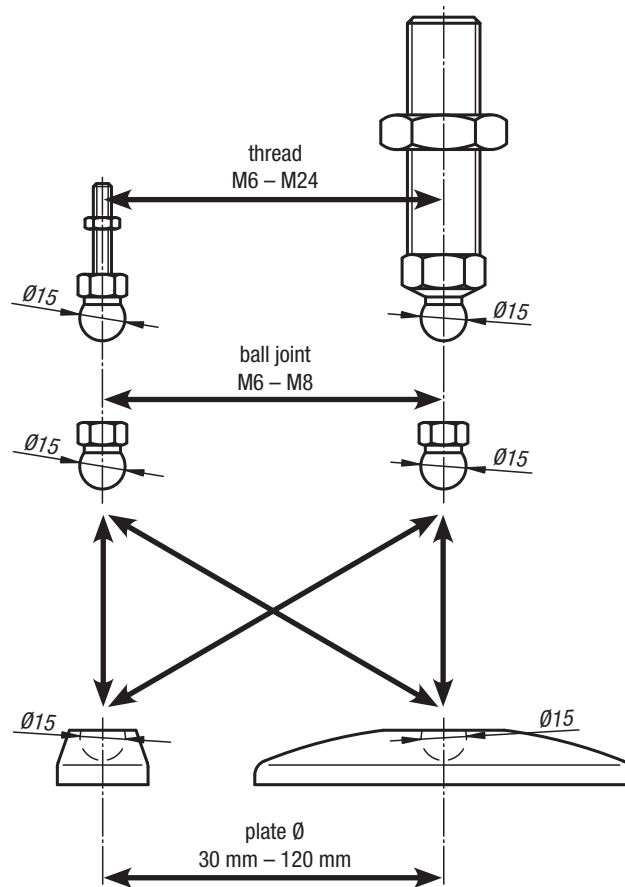
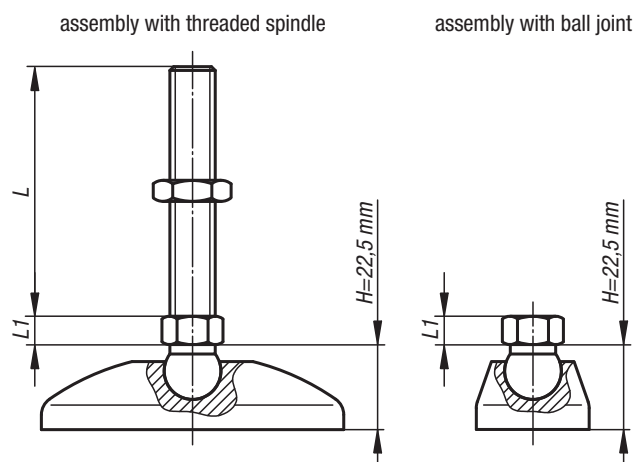

Fig. 2



Inclination angle of threaded spindle or ball joint:

