

## Description

### Material:

Steel version:  
indexing pin hardened: grade 5.8

Stainless steel version:  
indexing pin hardened: threaded sleeve 1.4305, indexing pin 1.4305.

Mushroom knob black grey thermoplastic.

### Version:

Steel version:  
indexing pin hardened, ground and black oxidised.

Stainless steel version:  
indexing pin hardened, ground and bright.

### Note:

Premium indexing plungers are characterized by more stringent manufacturing requirements for the indexing plungers and the threaded sleeve. In addition, a centring locator that can be used to increase the positioning accuracy is provided on the threaded sleeve. These indexing plungers are used when it is necessary to prevent shifting of the locked position by transverse forces and greater positioning accuracy is required. A new locking position can only be set after the pin has been manually disengaged. When high lateral forces are to be expected, the centring locator should be used.

### Assembly:

When using the threaded sleeve centring, it is recommended the receiving reamed hole be machined before tapping.  
The conical contact surface is aligned by the threaded sleeve and locking nut.

### On request:

Special versions and spacer rings.

### Accessory:

Matching tapered bush 03089.

### Drawing reference:

Form B: non-lockout type, with locknut  
Form D: lockout type, with locknut

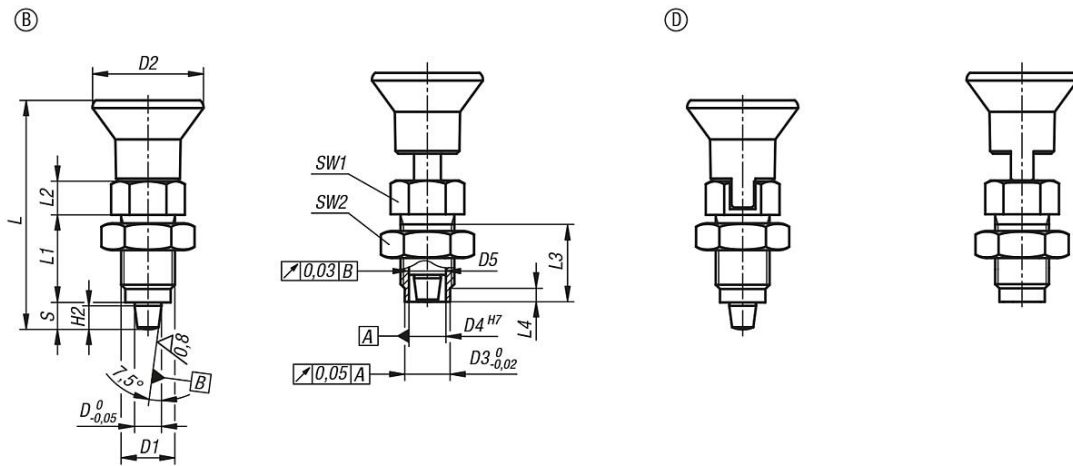

## Overview of items

Order No.	Form	Main material	D	D1	D2	D3	D4	D5	L	L1	L2	L3	L4	H2	Travel S	SW1	SW2	Spring force initial pressure F1 approx. N	Spring force final pressure F2 approx. N
03089-52105	B	steel	5	M10x1	21	8	6	6 -0,01/-0,02	43,5	17	7	15	3	4	5	13	17	5	12
03089-52206	B	steel	6	M12x1,5	25	10	8,5	8,5 -0,01/-0,03	51,7	20	8	17	3	5	6	14	19	6	14
03089-52308	B	steel	8	M16x1,5	33	13,5	11	11 -0,01/-0,03	68	26	10	23	4	7	8	19	24	15	35
03089-52410	B	steel	10	M20x1,5	33	17	11	11 -0,01/-0,03	74	28	12	25	4	9	10	22	30	15	34
03089-502105	B	stainless steel	5	M10x1	21	8	6	6 -0,01/-0,02	43,5	17	7	15	3	4	5	13	17	5	12
03089-502206	B	stainless steel	6	M12x1,5	25	10	8,5	8,5 -0,01/-0,03	51,7	20	8	17	3	5	6	14	19	6	14
03089-502308	B	stainless steel	8	M16x1,5	33	13,5	11	11 -0,01/-0,03	68	26	10	23	4	7	8	19	24	15	35
03089-502410	B	stainless steel	10	M20x1,5	33	17	11	11 -0,01/-0,03	74	28	12	25	4	9	10	22	30	15	34
03089-54105	D	steel	5	M10x1	21	8	6	6 -0,01/-0,02	43,5	17	7	15	3	4	5	13	17	5	12
03089-54206	D	steel	6	M12x1,5	25	10	8,5	8,5 -0,01/-0,03	51,7	20	8	17	3	5	6	14	19	6	14
03089-54308	D	steel	8	M16x1,5	33	13,5	11	11 -0,01/-0,03	68	26	10	23	4	7	8	19	24	15	35
03089-54410	D	steel	10	M20x1,5	33	17	11	11 -0,01/-0,03	74	28	12	25	4	9	10	22	30	15	34
03089-504105	D	stainless steel	5	M10x1	21	8	6	6 -0,01/-0,02	43,5	17	7	15	3	4	5	13	17	5	12
03089-504206	D	stainless steel	6	M12x1,5	25	10	8,5	8,5 -0,01/-0,03	51,7	20	8	17	3	5	6	14	19	6	14
03089-504308	D	stainless steel	8	M16x1,5	33	13,5	11	11 -0,01/-0,03	68	26	10	23	4	7	8	19	24	15	35
03089-504410	D	stainless steel	10	M20x1,5	33	17	11	11 -0,01/-0,03	74	28	12	25	4	9	10	22	30	15	34