



Description

Material:

Steel version:
Indexing pin hardened.
Sleeve 1.0403 weldable.
Indexing pin grade 5.8.

Stainless steel version:
Indexing pin hardened:
Sleeve 1.4301 weldable.
Indexing pin 1.4034.

Indexing pin not hardened:
Sleeve 1.4301 weldable.
Indexing pin 1.4305.

Key ring 1.4310, bright.

Version:

Steel version:
Indexing pin hardened, ground, black oxidised.

Stainless steel version:
Indexing pin hardened, ground and bright.
Indexing pin not hardened, ground and bright.

Note:

Indexing plungers are used to prevent any change in locking position due to lateral forces. A new locking position can only be set after the pin has been manually disengaged.

The key ring enables actuating the indexing plunger e.g. automatically (program-controlled) with the aid of a pneumatic cylinder or remote controlled with Bowden cables.

If the indexing plunger is welded on, the sleeve should be tack welded so that the spring is not thermally damaged due to high temperatures.

On request:

Special versions.

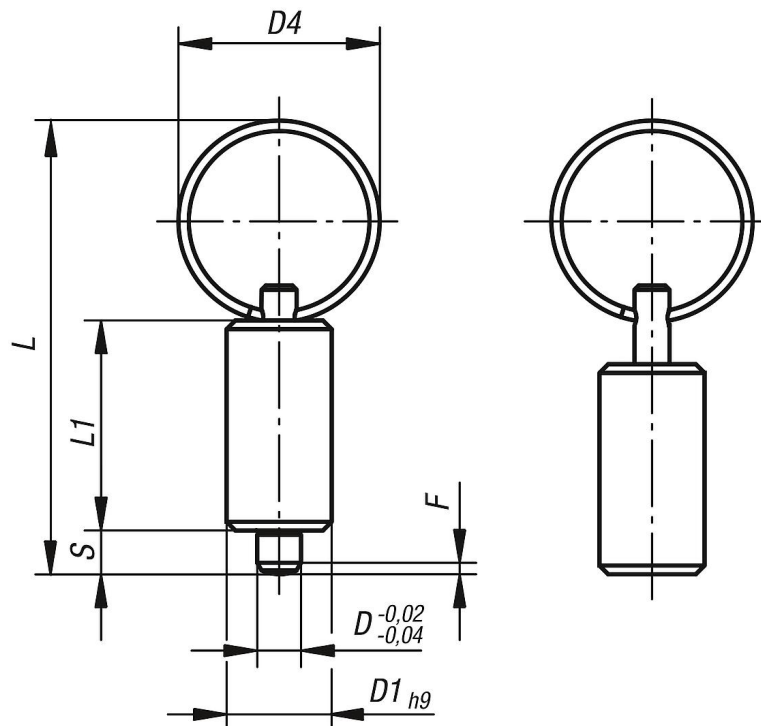

Overview of items

Indexing plungers without collar, steel, indexing pin hardened

Order No. steel hardened	Order No. stainless steel hardened	Order No. stainless steel not hardened	Form	D	D1	Travel S	D4	L	L1	Fx30°	Spring force initial pressure F1 approx. N	Spring force final pressure F2 approx. N
03098-4004	03098-04004	03098-14004	V	4	10	4	15	40	21	1	6	12
03098-4105	03098-04105	03098-14105	V	5	12	5	23	52	24	1,3	5	12
03098-4206	03098-04206	03098-14206	V	6	14	6	23	57	28	1,8	6	14
03098-4308	03098-04308	03098-14308	V	8	18	8	28	72	36	2,3	15	35
03098-4410	03098-04410	03098-14410	V	10	22	10	28	78	40	2,8	15	34