

Item description/product images



Description

Material:

Hub aluminium.
Bellows stainless steel.

Version:

Bright.

Note:

Clamping the hub with a grub screw is a cost-effective alternative to the metal bellows couplings with radial clamping hub (23000). Short mounting times and an easy installation even in difficult to reach places. Take note of the required tightening torque for the grub screw. To ease removal, a flat milled on the shaft is recommended.

Assembly:

The shaft to hub bore fit should be a transition fit. The play should be min. 0.01 mm and max. 0.04 mm. i.e:

shaft \varnothing 5 k6

bore \varnothing 5 G7.

Bores smaller than D1/D2 min. are possible, however an optimal transfer of the nominal torque is no longer guaranteed.

As the metal bellows are made of thin stainless steel plate, special care should be taken during installation and removal. Damages to the bellows can render the coupling unusable.

On request:

Hub bores D1 and D2 with separate tolerance class or range.

Drawings

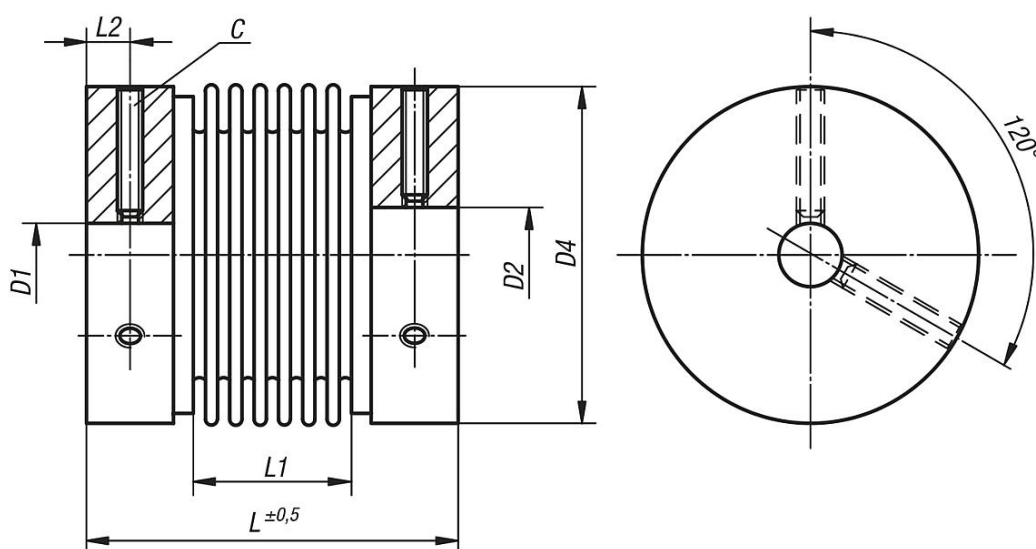

Overview of items

Order No.	Size	Nominal torque Nm	Moment of inertia (10^{-3} kgm ²)	Torsion resistance (10^{-3} Nm/arcmin)	Max. axial shaft displacement \pm	Max. lateral shaft displacement	Axial spring stiffness N/mm	Lateral spring stiffness N/mm
23002-0004	0,4	0,4	0,00019	50	0,35	0,1	10	15

Overview of items

Order No.	Size	Nominal torque Nm	Moment of inertia (10^{-3} kgm ²)	Torsion resistance (10^{-3} Nm/arcmin)	Max. axial shaft displacement \pm	Max. lateral shaft displacement	Axial spring stiffness N/mm	Lateral spring stiffness N/mm
23002-0005	0,9	0,9	0,00019	90	0,3	0,1	21	26
23002-0020	2	2	0,0029	230	0,5	0,1	15	15
23002-0040	4	4	0,0032	460	0,4	0,1	35	65
23002-0060	6	6	0,016	1100	0,6	0,25	45	60
23002-0080	8	9	0,028	1300	0,8	0,25	16	24

Order No.	Tightening torque of screws Nm	D1/D2 predrilled	D1/D2 min.	D1/D2 max.	D4	C (DIN 916)	L	L1	L2
23002-0004	1	3	3	8	16	M3	26	12	2,3
23002-0005	1	3	3	8	16	M3	27	13	2,3
23002-0020	4	5	5	15	25	M4	38	16	3,5
23002-0040	4	5	5	15	25	M4	39	17	3,5
23002-0060	8	6	6	20	35	M5	54	29	4,3
23002-0080	10	6	6	26	41	M6	54	26	5