

Item description/product images

INCH
Parts

Description

Material:

Handwheel, grey cast iron.
Grip steel.

Version:

Wheel rim turned and polished.

Note:

For the inch series, dimension D2 is in inches, all other dimensions are in mm.

On request:

Hubs with square socket or powder-coated handwheels.

Drawings

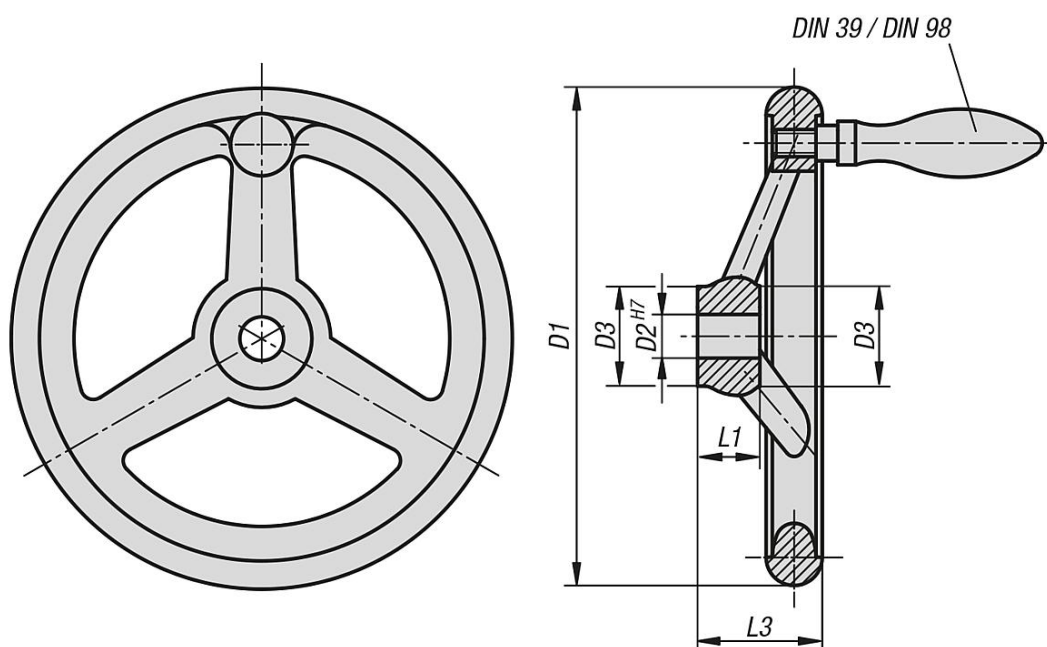

Overview of items

Handwheels gray cast iron DIN 950, without machine handle, inch

Order No.	D1	D2	D3	L1	L3	No. of spokes
06271-0080XCN	80	0,312	25	16	29	3
06271-0080XCO	80	0,375	25	16	29	3
06271-0100XCO	100	0,375	26	17	33	3
06271-0100XCP	100	0,5	26	17	33	3
06271-0125XCO	125	0,375	33	18	36	3
06271-0125XCP	125	0,5	33	18	36	3
06271-0140XCP	140	0,5	33	19	39	3
06271-0140XCQ	140	0,625	33	19	39	3
06271-0160XCP	160	0,5	37	20	40	3
06271-0160XCQ	160	0,625	37	20	40	3
06271-0180XCP	180	0,5	36	22	43	3
06271-0180XCQ	180	0,625	36	22	43	3
06271-0200XCQ	200	0,625	38	24	45	3

Overview of items

Order No.	D1	D2	D3	L1	L3	No. of spokes
06271-0200XCR	200	0,75	38	24	45	3
06271-0250XCR	250	0,75	46	28	50	5
06271-0250XCV	250	0,875	46	28	50	5
06271-0315XCV	315	0,875	54	33	56	5
06271-0315XCS	315	1	54	33	56	5
06271-0400XCS	400	1	68	38	63	5
06271-0500XCS	500	1	79	45	72	5

Handwheels gray cast iron DIN 950, with fixed machine handle, inch

Order No.	D1	D2	D3	L1	L3	No. of spokes	fixed grip DIN 39 Form E
06271-2080XCN	80	0,312	25	16	29	3	ø16 x M6 x 50
06271-2080XCO	80	0,375	25	16	29	3	ø16 x M6 x 50
06271-2100XCO	100	0,375	26	17	33	3	ø16 x M6 x 50
06271-2100XCP	100	0,5	26	17	33	3	ø16 x M6 x 50
06271-2125XCO	125	0,375	33	18	36	3	ø20 x M8 x 64
06271-2125XCP	125	0,5	33	18	36	3	ø20 x M8 x 64
06271-2140XCP	140	0,5	33	19	39	3	ø20 x M8 x 64
06271-2140XCQ	140	0,625	33	19	39	3	ø20 x M8 x 64
06271-2160XCP	160	0,5	37	20	40	3	ø25 x M10 x 80
06271-2160XCQ	160	0,625	37	20	40	3	ø25 x M10 x 80
06271-2180XCP	180	0,5	36	22	43	3	ø25 x M10 x 80
06271-2180XCQ	180	0,625	36	22	43	3	ø25 x M10 x 80
06271-2200XCQ	200	0,625	38	24	45	3	ø25 x M10 x 80
06271-2200XCR	200	0,75	38	24	45	3	ø25 x M10 x 80
06271-2250XCR	250	0,75	46	28	50	5	ø32 x M12 x 100
06271-2250XCV	250	0,875	46	28	50	5	ø32 x M12 x 100
06271-2315XCV	315	0,875	54	33	56	5	ø32 x M12 x 100
06271-2315XCS	315	1	54	33	56	5	ø32 x M12 x 100
06271-2400XCS	400	1	68	38	63	5	ø36 x M16 x 112
06271-2500XCS	500	1	79	45	72	5	ø36 x M16 x 112

Handwheels gray cast iron DIN 950, with revolving machine handle, inch

Order No.	D1	D2	D3	L1	L3	No. of spokes	revolving grip DIN 98 Form E
06271-4080XCN	80	0,312	25	16	29	3	ø16 x M6 x 54,5
06271-4080XCO	80	0,375	25	16	29	3	ø16 x M6 x 54,5
06271-4100XCO	100	0,375	26	17	33	3	ø16 x M6 x 54,5
06271-4100XCP	100	0,5	26	17	33	3	ø16 x M6 x 54,5
06271-4125XCO	125	0,375	33	18	36	3	ø20 x M8 x 67
06271-4125XCP	125	0,5	33	18	36	3	ø20 x M8 x 67
06271-4140XCP	140	0,5	33	19	39	3	ø20 x M8 x 67
06271-4140XCQ	140	0,625	33	19	39	3	ø20 x M8 x 67
06271-4160XCP	160	0,5	37	20	40	3	ø25 x M10 x 83
06271-4160XCQ	160	0,625	37	20	40	3	ø25 x M10 x 83
06271-4180XCP	180	0,5	36	22	43	3	ø25 x M10 x 83
06271-4180XCQ	180	0,625	36	22	43	3	ø25 x M10 x 83
06271-4200XCQ	200	0,625	38	24	45	3	ø25 x M10 x 83
06271-4200XCR	200	0,75	38	24	45	3	ø25 x M10 x 83
06271-4250XCR	250	0,75	46	28	50	5	ø32 x M12 x 105,5
06271-4250XCV	250	0,875	46	28	50	5	ø32 x M12 x 105,5
06271-4315XCV	315	0,875	54	33	56	5	ø32 x M12 x 105,5
06271-4315XCS	315	1	54	33	56	5	ø32 x M12 x 105,5
06271-4400XCS	400	1	68	38	63	5	ø36 x M16 x 117
06271-4500XCS	500	1	79	45	72	5	ø36 x M16 x 117

