

Item description/product images



Description

Material:

Polyamide fibreglass reinforced.

Version:

Black. Openable along inner radius.

Note:

Energy supply chains for safe guiding of flexible electric and data cables as well as pneumatic and hydraulic hoses. The modularly constructed chains can be easily shortened or extended.

The material is UV-resistant and therefore also suitable for outdoor applications.

Technical data:

Technical features in unsupported areas:

Speed: 10 m/s

Acceleration: 50 m/s²

Temperature range:

-30°C to +125°C

Drawings

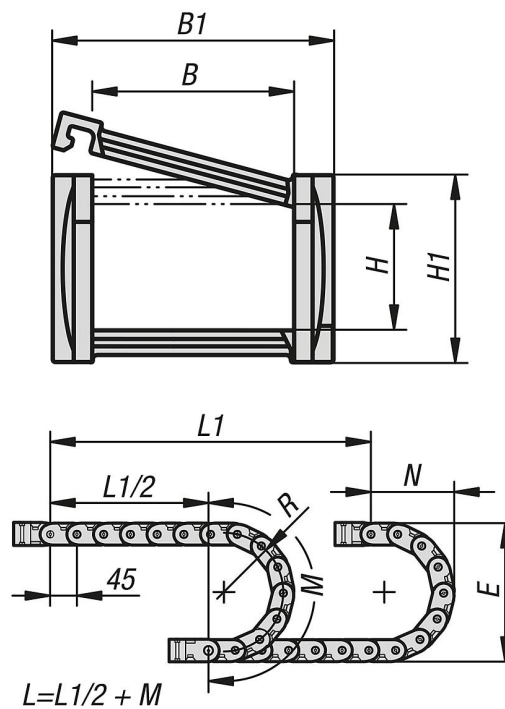

Drawings

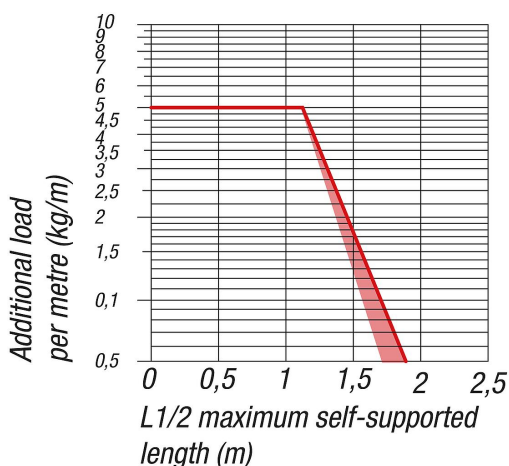

Overview of items

| Order No. | B | B1 | H | H1 | L | E | M | N | R | No. of links |
|--------------------|-----|-----|----|----|-----|-----|-----|-----|-----|--------------|
| 80850-20-250400501 | 40 | 57 | 25 | 38 | 990 | 138 | 250 | 115 | 50 | 22 |
| 80850-20-250400751 | 40 | 57 | 25 | 38 | 990 | 188 | 325 | 140 | 75 | 22 |
| 80850-20-250401001 | 40 | 57 | 25 | 38 | 990 | 238 | 405 | 165 | 100 | 22 |
| 80850-20-250600501 | 60 | 77 | 25 | 38 | 990 | 138 | 250 | 115 | 50 | 22 |
| 80850-20-250600751 | 60 | 77 | 25 | 38 | 990 | 188 | 325 | 140 | 75 | 22 |
| 80850-20-250601001 | 60 | 77 | 25 | 38 | 990 | 238 | 405 | 165 | 100 | 22 |
| 80850-20-251030501 | 103 | 120 | 25 | 38 | 990 | 138 | 250 | 115 | 50 | 22 |
| 80850-20-251030751 | 103 | 120 | 25 | 38 | 990 | 188 | 325 | 140 | 75 | 22 |
| 80850-20-251031001 | 103 | 120 | 25 | 38 | 990 | 238 | 405 | 165 | 100 | 22 |

| Order No. | Approx. weight kg/m | Connecting element | Tension relief | Divider |
|--------------------|---------------------|--------------------|----------------|-------------|
| 80850-20-250400501 | 0,9 | 80850-21-25040 | 80850-23-25 | 80850-22-25 |
| 80850-20-250400751 | 0,9 | 80850-21-25040 | 80850-23-25 | 80850-22-25 |
| 80850-20-250401001 | 0,9 | 80850-21-25040 | 80850-23-25 | 80850-22-25 |
| 80850-20-250600501 | 0,95 | 80850-21-25060 | 80850-23-25 | 80850-22-25 |
| 80850-20-250600751 | 0,95 | 80850-21-25060 | 80850-23-25 | 80850-22-25 |
| 80850-20-250601001 | 0,95 | 80850-21-25060 | 80850-23-25 | 80850-22-25 |
| 80850-20-251030501 | 1,15 | 80850-21-25103 | 80850-23-25 | 80850-22-25 |
| 80850-20-251030751 | 1,15 | 80850-21-25103 | 80850-23-25 | 80850-22-25 |
| 80850-20-251031001 | 1,15 | 80850-21-25103 | 80850-23-25 | 80850-22-25 |