



Description

Product description:

Rotary lever clamps are highly suited for use in cramped conditions. Due to the compactness of the rotary lever clamps, they can be used in a variety of ways in clamping fixtures with little use of space and thus often enable flexible solutions.

Material:

Housing and piston steel.

Version:

Housing black oxidised.

Piston hardened.

Note:

In the rotary lever clamps, the clamping lever is connected to the piston rod. The clamping lever is released and opened by means of spring tension for single-acting rotary lever clamps and by means of a pressure medium for double-acting clamps. The oil supply for the rotary lever clamps is via drilled channels.

When clamping with the rotary lever clamp, the clamping lever moves towards the workpiece with a straight stroke and clamps it. To release the workpiece, the clamping lever retracts so far that the workpiece can be removed vertically. The single stroke of a rotary lever clamp depends on the clamping lever selection.

The clamping elements must be checked regularly for dirt and cleaned if necessary. When selecting the installation position, it must be ensured that no swarf nests can form in the swivel area of the lever of the rotary lever clamp.

The flange surface of the rotary lever clamp should be adapted to the height of the workpiece during installation and a horizontal positioning of the clamping point should be available.

By positioning the rotary lever clamp correctly, workpiece tolerances can be optimally compensated for despite the short clamping lever.

Large forces can be generated with the rotary lever clamps. It must be ensured that the workpieces and clamping fixtures are designed for these loads.

Rotary lever clamps can be fitted with individual tension levers. The clamping force of a rotary lever clamp is dependent on the lever length.

The tension lever for the rotary lever clamp is not supplied.

Follow safety instructions.

Type of operation:

Drilled channels.

Technical data:

Max. operating pressure: 400 bar.

Assembly:

See mounting contour.

Advantages:

- No lateral forces during clamping.

- Low mounting dimensions.
- Wide selection of levers.
- Collision-free accessibility to the workpiece.
- Lineless pressure supply.

On request:

Larger piston diameters, longer strokes and with position control.

Supplied with:

Supplied with 4 DIN EN ISO 4762 cap screws, grade 8.8.

Accessory:

Tension levers for rotary lever clamps 04624-30.

Drawing reference:

- 1) Tension lever length (see 04624-30)
- 2) Travel (see 04624-30)
- 3) see accessories
- 4) Mounting contour
- 5) Rounded edges
- 6) Loosen
- 7) Clamping alternative
- 8) Clamping

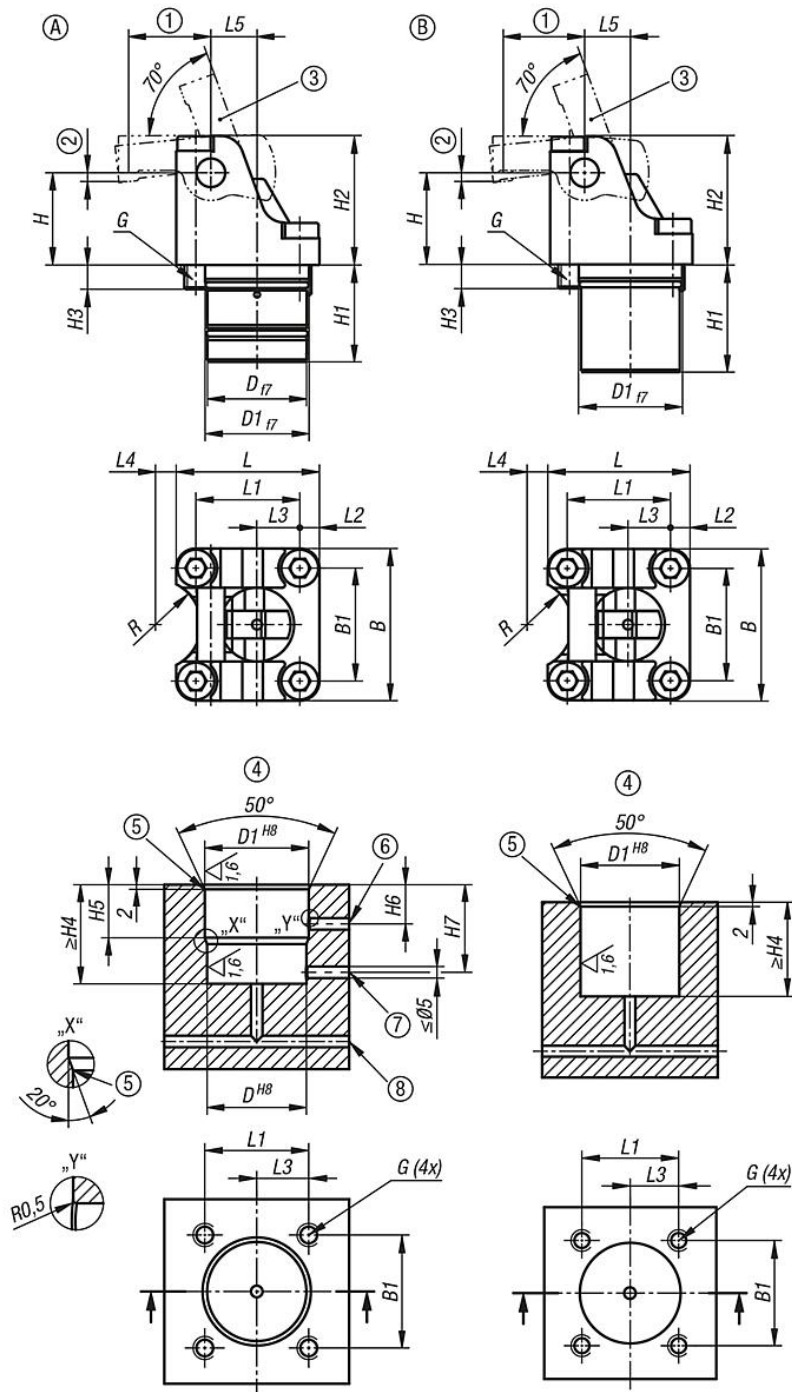

Calculating the effective clamping force with hydraulic rotary lever clamps:

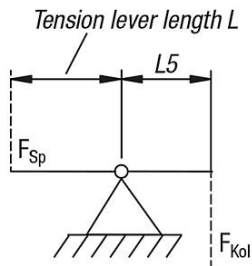

Effective clamping force F_{Sp} is dependent on piston force F_{Kol} and tension lever length L

Calculation:

$$\text{Clamping force } F_{Sp} = \frac{F_{Kol} \times L5}{L}$$

$$\text{Clamping force } F_{Sp} = \frac{2.5 \text{ kN} \times 10 \text{ mm}}{18 \text{ mm}} = 1.39 \text{ kN}$$

Example:

- Rotary lever clamp cylinder size 16
- Operating pressure 100 bar
- Piston force F_{Kol} at 100 bar = 2.5 kN
- Dimension $L5$ acc. to table = 10 mm
- Tension lever length $L = 18$ mm
- Resulting effective clamping force $F_{Sp} = 1.39$ kN

Overview of items

Order No.	Form	Piston Ø	Form definition	Connection type	B	B1	D	D1	G	G1	H	H1	H2	H3	H4
04624-20-121304	A	12	double-acting	drilled channels	27	19,5	19,4	20	M4	M4x8	15	21	21	7,5	21,5
04624-20-161304	A	16	double-acting	drilled channels	34	25	23	24	M5	M5x12	20	26	28	10,5	26,5
04624-20-201304	A	20	double-acting	drilled channels	40	30	29	30	M6	M6x10	25	32,5	35	9	33
04624-20-251304	A	25	double-acting	drilled channels	52	38,5	35	36	M8	M8x12	31,25	37	43,75	11,5	38
04624-20-321304	A	32	double-acting	drilled channels	66	49	43	45	M10	M10x15	40	42	56	13	43
04624-20-401304	A	40	double-acting	drilled channels	78	59	53	55	M12	M12x18	50	47	70	17,5	48
04624-20-122304	B	12	single-acting	drilled channels	27	19,5	-	20	M4	M4x8	15	23	21	7,5	23,5
04624-20-162304	B	16	single-acting	drilled channels	34	25	-	24	M5	M5x12	20	26	28	10,5	26,5
04624-20-202304	B	20	single-acting	drilled channels	40	30	-	30	M6	M6x10	25	32,5	35	9	33
04624-20-252304	B	25	single-acting	drilled channels	52	38,5	-	36	M8	M8x12	31,25	37	43,75	11,5	38
04624-20-322304	B	32	single-acting	drilled channels	66	49	-	45	M10	M10x15	40	47	56	11,5	48
04624-20-402304	B	40	single-acting	drilled channels	78	59	-	55	M12	M12x18	50	55	70	17,5	56

Order No.	Form	Piston Ø	H5	H6	H7	L	L1	L2	L3	L4	L5	R	Piston force at 100 bar (kN)	Piston force at 400 bar (kN)	Volume (cm³)	Effective piston area (cm²)
04624-20-121304	A	12	14	11	23	26	18,5	3,75	8,75	7,5	7,5	10,6	1,7	7	1,06	1,77
04624-20-161304	A	16	17	13	26	32	23	4,5	9,5	10	10	14,2	2,8	11,3	2,03	2,83
04624-20-201304	A	20	17	14	31	40	30	5	13,5	11	12,5	15,7	4,5	18	4,52	4,52
04624-20-251304	A	25	20	15	33	49	35,5	6,75	14,75	11	15,63	18,7	6,15	24,6	8,82	6,15
04624-20-321304	A	32	23	17	38	62	45	8,5	18,5	9	20	19,7	10,1	40,6	16,27	10,17
04624-20-401304	A	40	25	19	40	74	55	9,5	21,5	12	25	24,7	15,9	63,6	31,8	15,9
04624-20-122304	B	12	-	-	-	26	18,5	3,75	8,75	7,5	7,5	10,6	1,1	4,4	0,68	1,13
04624-20-162304	B	16	-	-	-	32	23	4,5	9,5	10	10	14,2	1,9	8	1,61	2,01
04624-20-202304	B	20	-	-	-	40	30	5	13,5	13,5	12,5	15,7	3	12,4	3,14	3,14
04624-20-252304	B	25	-	-	-	49	35,5	6,75	14,75	11	15,63	18,7	4,7	19,4	6,14	4,91
04624-20-322304	B	32	-	-	-	62	45	8,5	18,5	9	20	19,7	7,8	32	12,9	8,04
04624-20-402304	B	40	-	-	-	74	55	9,5	21,5	12	25	24,7	12,3	50	25,2	12,57