

Item description/product images

**Description****Material:**

Lever steel plate.
Hinge pins stainless steel.

Version:

Lever parts electro zinc-plated.
Pneumatic cylinder, double-acting.
With magnetic piston for end position feedback.
Clamp trivalent passivated.
Complete with tempered, trivalent passivated thrust screw with protective cap.

Note:

Pneumatic clamps have the following advantages compared to hand clamps:
The operator is relieved of frequent clamping.
Several clamps can be activated at the same time and can be closed in a specific sequence.
Single or multiple clamps can be activated from varying positions by machine control or hand control.
Because of the toggle system:

- the clamp remains closed if the air supply fails.
- the air consumption is low due to the large end ratio.
- pivoting the clamping arm achieves a large opening travel.
- optimum force and movement ratios are achieved.

VL = air consumption per complete cycle in dm³ at 6 bar.

Selection criteria:

To select the correct size of pneumatic clamps, the possible clamping force at 6 bar (any compressed media are permissible, maximum pressure 10 bar) is specified besides the retaining force. F3 is the possible clamping force that the clamp exerts on the end of the clamping arm, F4 the force it exerts on the fulcrum side.

Control:

The schematic diagram for the simplest control of one or several pneumatic clamps is shown here. When constructing complete switching systems consult a well known manufacturer of pneumatic valves who can also supply all the required connectors and fittings.

Note:

The forces F1 and F2 specified in the table are holding forces.
F3 and F4 are clamping forces.

Drawings

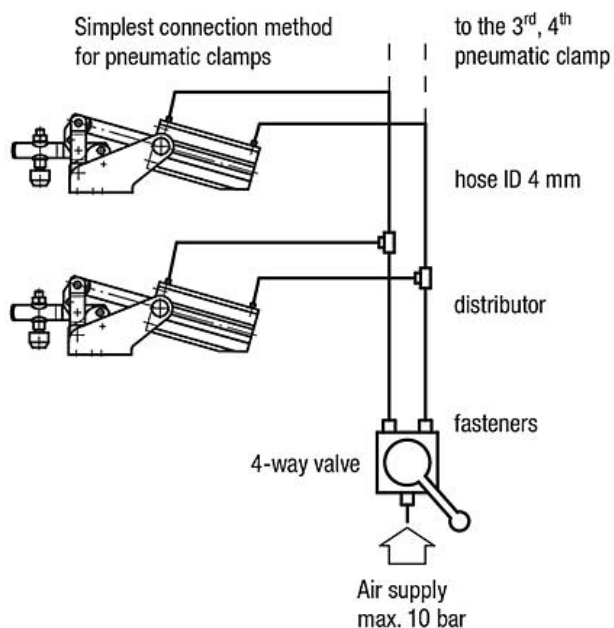
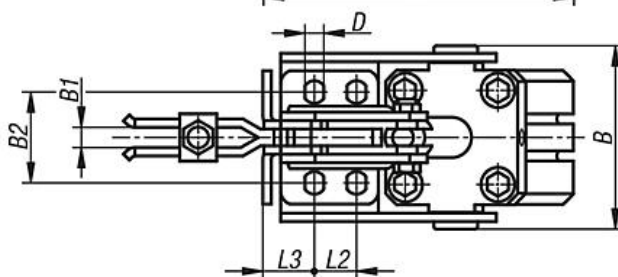
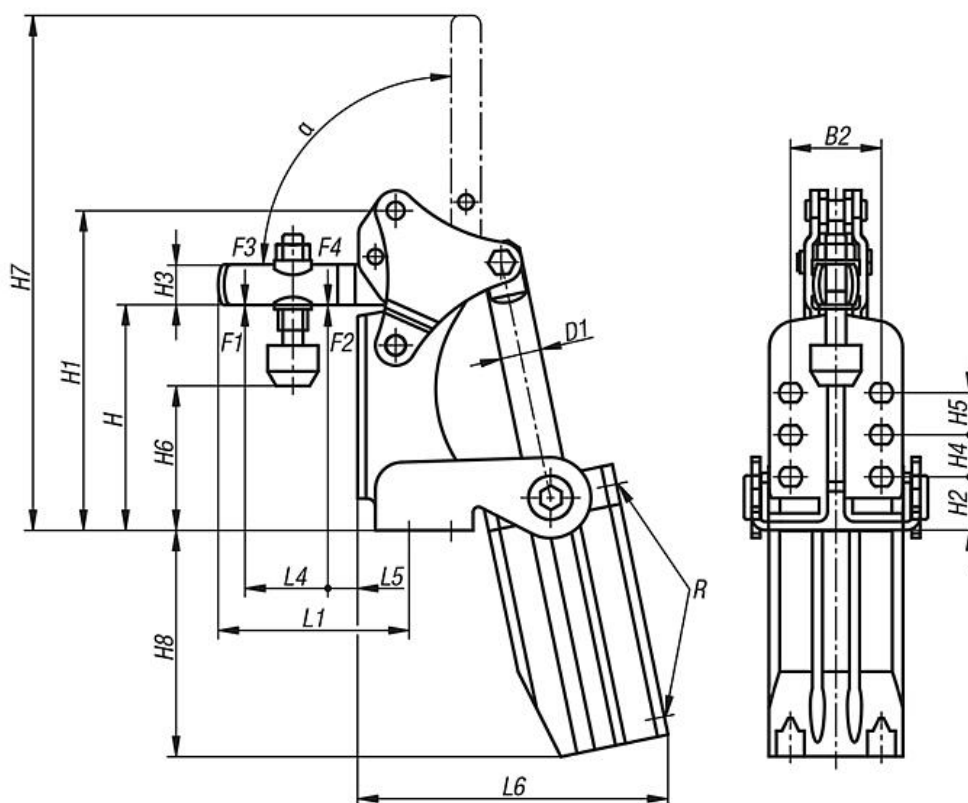

Overview of items

| Order No. | B | B1 | B2 | D | D1 | H | H1 | H2 | H3 | H4 | H5 | H6 | H7 | H8 | L1 | L2 | L3 | L4 | L5 | L6 | R | α | F1 kN | F2 kN | F3 kN | F4 kN | VL | suitable thrust screws |
|-----------|------|----|----|-----|----|------|-----|------|----|------|------|--------------|-------|------|------|------|------|----|------|-------|------|----------|----------|----------|----------|----------|------|---------------------------|
| 05332-02 | 54,5 | 6 | 27 | 5,6 | 12 | 65 | 94 | 15,8 | 12 | 12,5 | 12,5 | 38,4 - 45,0 | 143,5 | 67,5 | 56,5 | 12,5 | 15,3 | 25 | 6,5 | 93 | M5 | 90° | 1 | 1,2 | 0,7 | 1 | 0,26 | M6x35 |
| 05332-03 | 62,5 | 8 | 25 | 6,5 | 16 | 68,7 | 107 | 17,5 | 18 | 16 | - | 38,0 - 46,5 | 184 | 78 | 80,5 | 16 | 16,5 | 36 | 12,5 | 112,5 | G1/8 | 90° | 1 | 2,5 | 0,65 | 1,1 | 0,35 | M8x45 |
| 05332-04 | 77,5 | 10 | 45 | 8,5 | 16 | 100 | 144 | 20,5 | 20 | 32 | 32 | 51,0 D0 80,0 | 245 | 80 | 102 | 32 | 17,5 | 49 | 19 | 139 | G1/4 | 90° | 2 | 3 | 1,5 | 2,2 | 0,8 | M8x65 |