

Item description/product images



Description

Material:

Clamping angle die-cast zinc.
Cam lever cast aluminium.
Body steel.

Version:

Cam lever, black powder-coated.
Metal parts, black oxidised.
Slot key, electro zinc-plated.

Note:

The clamping angles are used for connecting two profiles of the same series that have contact on the side faces and cross at any angle.

Loosening the screw releases both clamps allowing free rotation and sliding along the slots.

The clamping angles are generally used in pairs or in combination with a joint angle.

Drawings

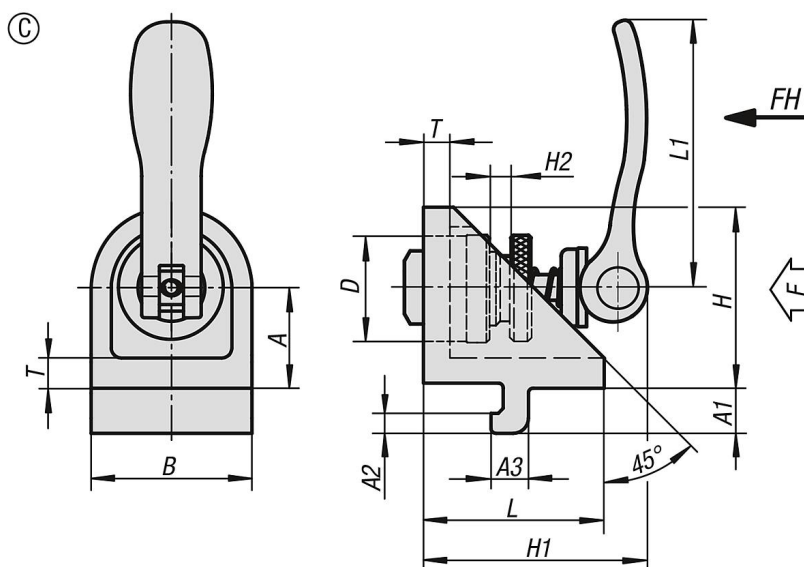

Overview of items

Order No.	Type	Slot width	Form	Version 1	A	A1	A2	A3	B	D	H	H1	H2	L	L1	T	Clamping force F (kN)	Hand force FH N
10265-0615	I	6	C	with eccentric clamp	15	6,3	3	5,7	24	15	27	34	6	27	36,2	5	2	90
10265-0820	I	8	C	with eccentric clamp	20	9	4	7,5	32	20	36	44	8	36	52,3	6	3	100

