

Item description/product images



**Description**

**Material:**

Form C and F:  
Ball steel, ball seat high-carbon steel.

Form G and J:  
Ball high-carbon steel, ball seat steel.

**Version:**

Form C and F:  
Ball hardened and black oxidised, ball seat phosphated.

Form G and J:  
Ball phosphated, ball seat hardened and black oxidised.

**Note:**

The self-aligning pads serve as stops, rests and thrust pads in fixture construction. The seating face returns to the start position when the load is removed.

Ball secured against rotation.

**Drawing reference:**

Form C: external thread, flattened ball, smooth

Form F: external thread, flattened ball, diamond grip

Form G: press fit, flattened ball, smooth

Form J: press fit, flattened ball, diamond grip

Drawings

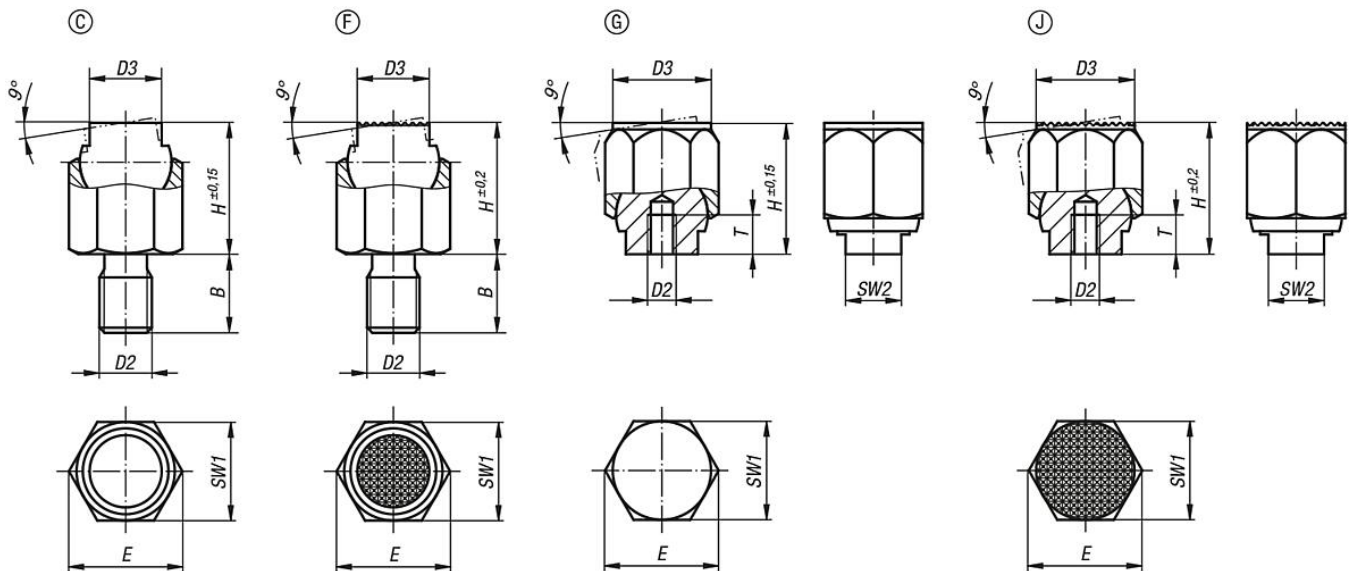

Overview of items

Order No.	Form	B	D2	D3	H	T	E	SW1	SW2	Ball-Ø	Load rating max. kN (static load only)
02081-106	C	9	M6	7	13	-	11,5	10	-	9	8
02081-108	C	12	M8	9,5	18	-	15	13	-	12	16
02081-110	C	15	M10	14	25	-	21,9	19	-	17	32
02081-112	C	18	M12	20	36	-	31,2	27	-	25	64
02081-116	C	24	M16	22	40	-	34,6	30	-	28	90
02081-306	F	9	M6	7	13	-	11,5	10	-	9	8

## Overview of items

Order No.	Form	B	D2	D3	H	T	E	SW1	SW2	Ball-Ø	Load rating max. kN (static load only)
02081-308	F	12	M8	9,5	18	-	15	13	-	12	16
02081-310	F	15	M10	14	25	-	21,9	19	-	17	32
02081-312	F	18	M12	20	36	-	31,2	27	-	25	64
02081-316	F	24	M16	22	40	-	34,6	30	-	28	90
02081-403	G	-	M3	9	13	5	11,5	10	6	9	8
02081-404	G	-	M4	12	18	6	15	13	8	12	16
02081-405	G	-	M5	18	25	8	21,9	19	10	17	32
02081-406	G	-	M6	26	36	10	31,2	27	16	25	64
02081-408	G	-	M8	30	40	12	34,6	30	17	28	90
02081-603	J	-	M3	9	13	5	11,5	10	6	9	8
02081-604	J	-	M4	12	18	6	15	13	8	12	16
02081-605	J	-	M5	18	25	8	21,9	19	10	17	32
02081-606	J	-	M6	26	36	10	31,2	27	16	25	64
02081-608	J	-	M8	30	40	12	34,6	30	17	28	90