

Technical information on linear actuators

These linear actuators are efficient, economical and universally applicable. They ideally combine high rigidity, low deflection, high loads and easy handling. Four sizes are available for different applications and loads (tube sizes from Ø18 mm to Ø50 mm).

Features:

- Standard travel over 2000 mm possible
- Position accuracy up to ±0.2 mm / 300 mm
- Travel speed up to 1.5 m/min
- Drive by trapezoid thread spindle
- Mounting position optional

Technical description:

In a tube, a threaded spindle mounted on bearings with guide nut converts a rotation into linear movement of a carriage. The nut has a carrier key to prevent it turning.

Mounting the linear actuator:

Depending on the mounting position and application, linear actuators can be mounted using our tube clamping elements.

Speed:

n = required spindle r.p.m.
 max. spindle rpm with:
 plain bearing 80 rpm.
 ball bearing 250 rpm.

Type E	Pitch mm
18	2
30	3
40	4
50	4

$$n \text{ [r.p.m.]} = \frac{\text{Speed [m/min]} \times 1000[\text{mm}]}{\text{Spindle pitch [mm]}}$$

No-load torques:

Type E	Spindle with plain bearing [Nm]	Spindle with ball bearings [Nm]
18	-	0,20
30	0,45	0,35
40	0,65	0,50
50	1,20	0,90

Load data*:

- F force [N]
- M moment [Nm]
- I geom. moment of inertia [cm⁴]

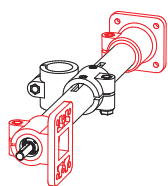
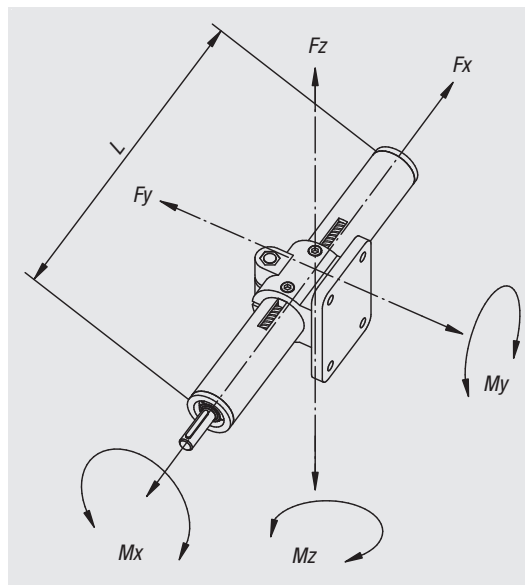

Length	Fx	Fy	Fz
	500	500/1000/1500	500/1000/1500
Type E 18	400	90 / 10 / -	60 / 8 / -
Type E 30	800	500 / 60 / 10	500 / 50 / 9
Type E 40	1000	2100 / 250 / 60	1900 / 140 / 50
Type E 50	1700	3000 / 600 / 140	3000 / 600 / 140

Type E	Mx	My	Mz	Iy	Iz
18	1,5	4	4	0,22	0,27
30	6	15	15	1,34	1,56
40	14	40	40	4,58	5,24
50	30	65	65	11,31	12,32