

Item description/product images



Description

Material:

Joint die-cast zinc.
Fastenings die-cast zinc.
Spacer rings stainless steel.
Tapped bushes and countersunk screws steel.
Handle die-cast zinc DIN EN 12844. Steel parts stainless steel 1.4305.
The 40x80 and 45x90 joints are made from aluminium.

Version:

Joint painted aluminium tone.
Fasteners electro zinc-plated.
Spacer rings bright.
Tapped bushes and countersunk screws electro zinc-plated.
Handle powder-coated. Steel parts bright stainless steel.

Note:

Joints for connecting two profiles at any angle.
The adjustment range is 0° to 180°. The joint can also be used as a heavy hinge.

When the spacer rings are inserted, the joint can move freely. When these are removed, the joint can be used as a rigid angle element. The joints are particularly suitable for use as adjustable brackets, swivel arms or similar applications.

Drawings

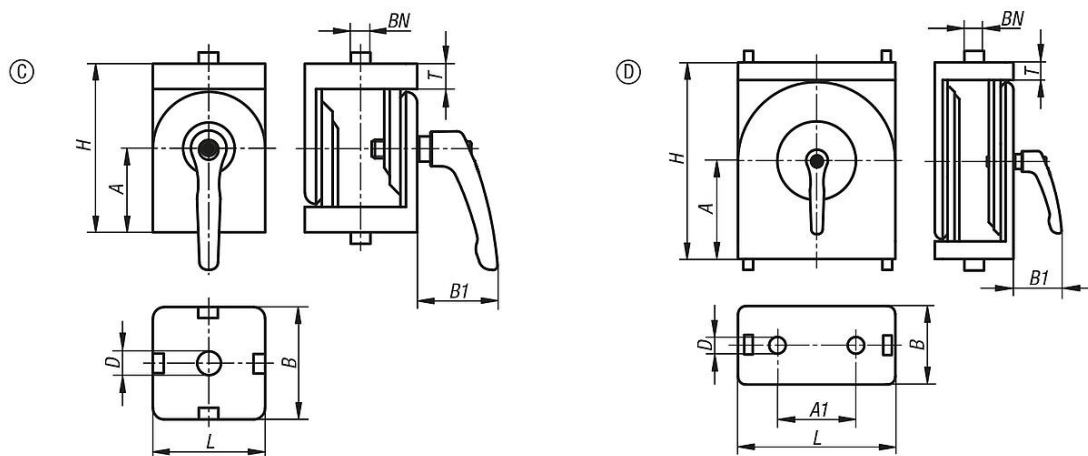

Overview of items

Order No.	Type	BN=Slot width	Form	A	A1	B	B1	D	H	L	T
10270-1063030	I	6	C	22,5	-	30	31	6,4	45	30	7
10270-1084040	I	8	C	30	-	40	31	8,4	60	40	9
10270-2084080	I	8	D	50	40	40	31	8,4	100	80	9
10270-1104545	B	10	C	30	-	45	42,5	8,5	60	45	8
10270-2104590	B	10	D	50	45	45	42,5	8,5	100	90	9

