

## Item description/product images

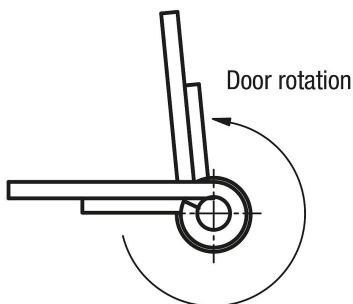

Hinges with opening spring

**Description****Material:**

Aluminium 6060 T5.  
Cover plug PA 6.6.

**Version:**

Black anodised.  
Colourless anodised.

**Note:**

The hinges are fitted with an integrated steel tension spring. This enables automatic opening and closing of doors and hatches.

Due to the same dimensions and appearance, the free-swinging hinges can be combined with the hinges with springs.

Opening angle 270°.

**Opening spring torque:**

$M(0^\circ) : 0.92 \text{ Nm} / M(90^\circ) : 0.7 \text{ Nm} / M(180^\circ) : 0.44 \text{ Nm}$

Fastened using DIN 7991 countersunk screws.

The loading values given for the hinges are non-binding reference values without consideration of safety factors and exclude any liability. The values given are for information purposes only and do not constitute a legally binding assurance of properties.

These load values were determined under laboratory conditions. Each user must determine individually whether the hinge is suitable for the respective application. Different materials onto which the hinges are installed and the type of mounting, weather conditions and wear can influence the determined values.

**Temperature range:**

From -20°C to +80°C

Drawings

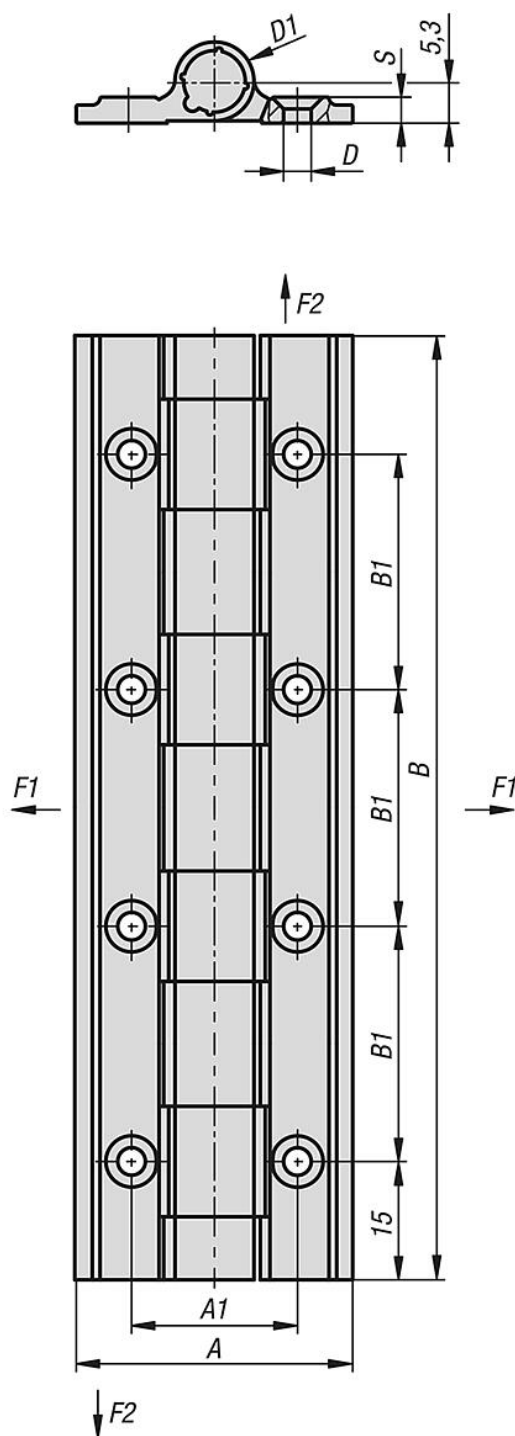

Overview of items

Order No.	Version 1	Main colour	Surface finish body	A	A1	B	B1	D	D1	S	F1 N	F2 N	Kind of fastening
27907-02-351200	spring open	colourless	anodised	35	21	120	30	3,5	10	3,3	3700	9900	fastening holes
27907-02-3512001	spring open	black	anodised	35	21	120	30	3,5	10	3,3	3700	9900	fastening holes
27907-02-351202	-	colourless	anodised	35	21	120	30	3,5	10	3,3	3700	9900	fastening holes
27907-02-3512021	-	black	anodised	35	21	120	30	3,5	10	3,3	3700	9900	fastening holes

Overview of items

---