

## Item description/product images



## Description

**Material:**

Polyamide fibreglass reinforced.

**Version:**

Black. Openable from both sides.

**Note:**

Energy supply chains for safe guiding of flexible electric and data cables as well as pneumatic and hydraulic hoses. The modularly constructed chains can be easily shortened or extended.

The material is UV-resistant and therefore also suitable for outdoor applications.

**Technical data:**

Technical features in unsupported areas:

Speed: 10 m/s

Acceleration: 50 m/s<sup>2</sup>

**Temperature range:**

-30°C to +125°C

## Drawings

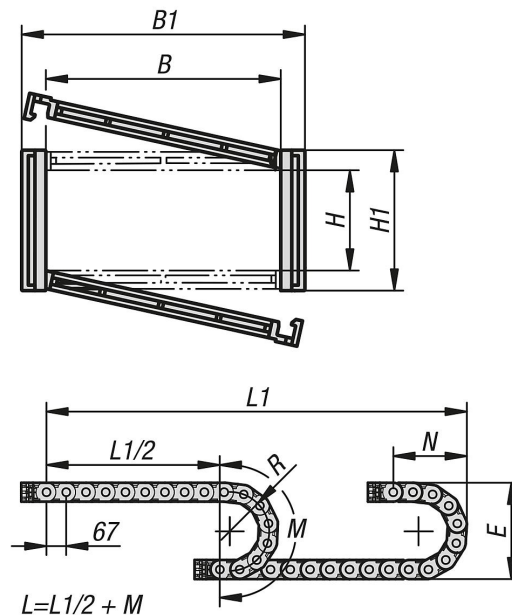

Drawings

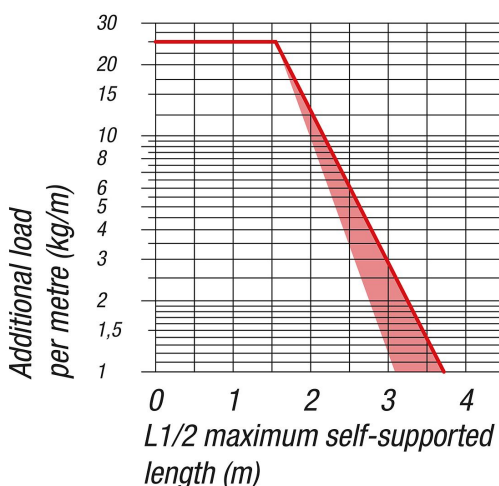

Overview of items

Order No.	B	B1	H	H1	L	E	M	N	R	No. of links
80850-90-451001003	100	122	45	64	1005	264	450	200	100	15
80850-90-451001503	100	122	45	64	1005	364	605	250	150	15
80850-90-451002003	100	122	45	64	1005	464	765	300	200	15
80850-90-451501003	150	172	45	64	1005	264	450	200	100	15
80850-90-451501503	150	172	45	64	1005	364	605	250	150	15
80850-90-451502003	150	172	45	64	1005	464	765	300	200	15
80850-90-452001003	200	222	45	64	1005	264	450	200	100	15
80850-90-452001503	200	222	45	64	1005	364	605	250	150	15
80850-90-452002003	200	222	45	64	1005	464	765	300	200	15

Order No.	Approx. weight kg/m	Connecting element	Tension relief	Divider
80850-90-451001003	1,87	80850-91-45100	80850-93-45100	80850-92-45
80850-90-451001503	1,87	80850-91-45100	80850-93-45100	80850-92-45
80850-90-451002003	1,87	80850-91-45100	80850-93-45100	80850-92-45
80850-90-451501003	2,13	80850-91-451150	80850-93-45150	80850-92-45
80850-90-451501503	2,13	80850-91-451150	80850-93-45150	80850-92-45
80850-90-451502003	2,13	80850-91-451150	80850-93-45150	80850-92-45
80850-90-452001003	2,39	80850-91-451200	80850-93-45200	80850-92-45
80850-90-452001503	2,39	80850-91-451200	80850-93-45200	80850-92-45
80850-90-452002003	2,39	80850-91-451200	80850-93-45200	80850-92-45