

Item description/product images



Description

Material:

Stainless steel 1.4305.

Version:

Milled toothing, straight teeth.  
Engagement angle 20°, bright.

Note:

The spur gears have a centre bore or pilot hole (this can vary due to manufacturing methods). For this reason, the dimension D2 max. given in the table is the maximum diameter of the bore with which the spur gears are supplied. This pilot/centre bore can be amended by the customer to produce a reamed bore, reamed bore with keyway or a tapped hole. Alternatively, customers can also use bushes to reduce the bore diameter.

Drawing reference:

Form A: with hub  
Form B: without hub

Drawings

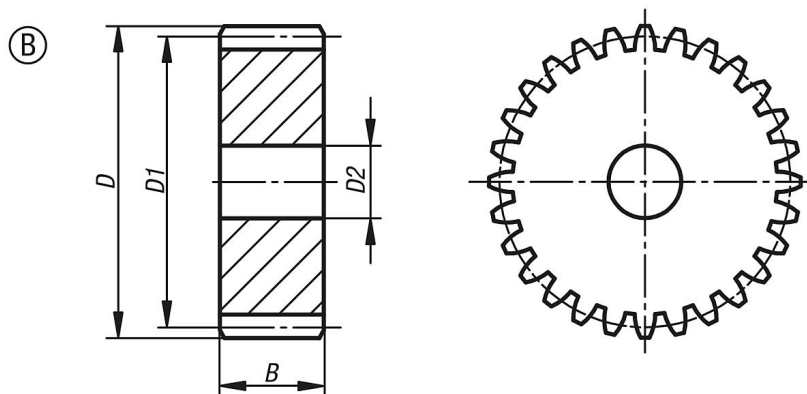

Overview of items

Order No.	Form	Form definition	Module	No. of teeth	B	D	D1	D2 max.
22400-20-1215170080	B	without hub	1,5	80	17	123	120	16
22400-20-1215170120	B	without hub	1,5	120	17	183	180	16