

Item description/product images

**Description****Material:**

Body carbon steel.

Ball rust and acid resistant steel.

Inserts:

Form C, F, M tool steel

Form K POM

Form E stainless steel.

Form O stainless steel diamond impregnated.

Form P stainless steel with polyurethane surface.

Version:

Body tempered, black oxidised.

Ball hardened, bright.

Inserts:

Form C, F hardened, black oxidised.

Form M with carbide serrations, black oxidised.

Form K white.

Form E hardened, bright.

Form O diamond impregnated surface comparable to 100 grade abrasive grit.

Form P polyurethane surface, hardness 60 Shore.

Note:

Self-aligning pads are used to support and clamp unmachined and machined workpieces.

In addition, they serve as stops, supports and thrust pads in fixtures and toolmaking.

The ball can be removed from the housing by applying light pressure to the socket head screw.

Ball secured against rotation.

Advantages:

Highly cost-effective as inserts can be exchanged.

The built-in O-ring holds the ball in place and keeps dirt and foreign particles out, ensuring uniform movement.

Drawing reference:

Form C: flattened steel insert, smooth

Form E: flattened stainless steel insert, smooth

Form F: gripper face

Form K: flattened POM insert, smooth

Form M: gripper face, with carbide serrations

Form O: stainless steel insert diamond impregnated

Form P: stainless steel insert with polyurethane surface

Item description/product images



Item description/product images



Item description/product images



Drawings

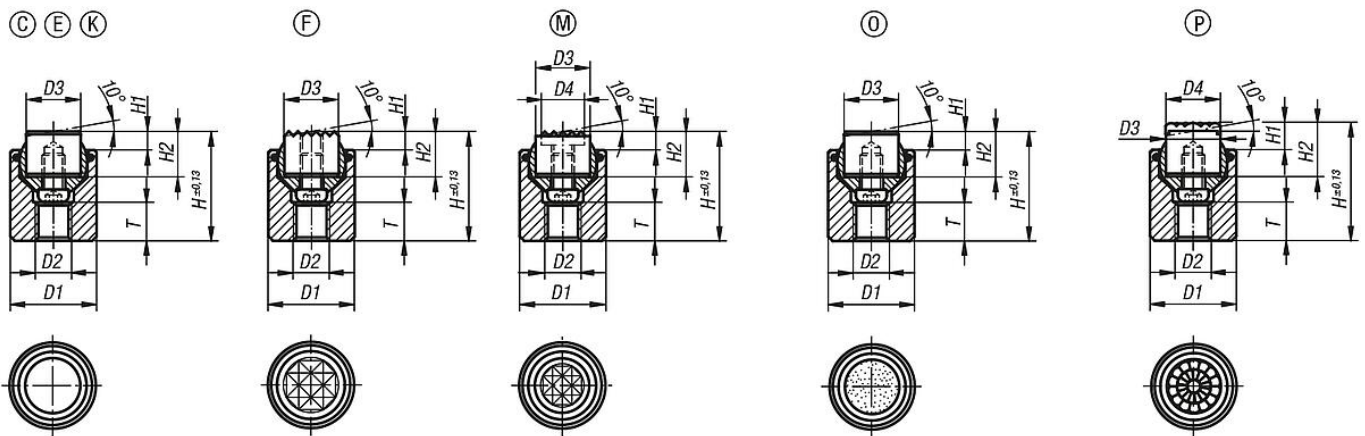

Overview of items

Order No.	Form	D1	D2	D3	H	H1	H2	T	Ball-Ø	Load rating max. kN (static load only)	Order No. steel insert
02003-117X022	C	17	M6	10	22	4	10	7	13	28	07113-10108
02003-119X024	C	19	M8	12	24	4	10	8	15	39	07113-12108
02003-124X028	C	24	M10	16	28	4	10	8	20	58	07113-16108
02003-130X030	C	30	M12	20	30	4	10	9	23	95	07113-20108
02003-136X036	C	36	M12	25	36	4	10	11	28	136	07113-25108

Order No.	Form	D1	D2	D3	H	H1	H2	T	Ball-Ø	Load rating max. kN (static load only)	Order No. stainless steel insert
02003-217X022	E	17	M6	10	22	4	10	7	13	28	07113-10102
02003-219X024	E	19	M8	12	24	4	10	8	15	39	07113-12102
02003-224X028	E	24	M10	16	28	4	10	8	20	58	07113-16102
02003-230X030	E	30	M12	20	30	4	10	9	23	95	07113-20102
02003-236X036	E	36	M12	25	36	4	10	11	28	136	07113-25102

Order No.	Form	D1	D2	D3	H	H1	H2	T	Ball-Ø	Load rating max. kN (static load only)	Order No. gripper
02003-317X022	F	17	M6	10	22	4	10	7	13	28	07113-1010

Overview of items

Order No.	Form	D1	D2	D3	H	H1	H2	T	Ball-Ø	Load rating max. kN (static load only)	Order No. gripper
02003-319X024	F	19	M8	12	24	4	10	8	15	39	07113-1210
02003-324X028	F	24	M10	16	28	4	10	8	20	58	07113-1610
02003-330X030	F	30	M12	20	30	4	10	9	23	95	07113-2010
02003-336X036	F	36	M12	25	36	4	10	11	28	136	07113-2510

Order No.	Form	D1	D2	D3	H	H1	H2	T	Ball-Ø	Load rating max. kN (static load only)	Order No. POM insert
02003-717X022	K	17	M6	10	22	4	10	7	13	4	07113-10109
02003-719X024	K	19	M8	12	24	4	10	8	15	7	07113-12109
02003-724X028	K	24	M10	16	28	4	10	8	20	14	07113-16109
02003-730X030	K	30	M12	20	30	4	10	9	23	27	07113-20109
02003-736X036	K	36	M12	25	36	4	10	11	28	47	07113-25109

Order No.	Form	D1	D2	D3	D4	H	H1	H2	T	Ball-Ø	Load rating max. kN (static load only)	Order No. gripper
02003-917X022	M	17	M6	10	7,9	22	4	10	7	13	28	07113-10107
02003-919X024	M	19	M8	12	9,5	24	4	10	8	15	39	07113-12107
02003-924X028	M	24	M10	16	12,7	28	4	10	8	20	58	07113-16107
02003-930X030	M	30	M12	20	15,9	30	4	10	9	23	95	07113-20107
02003-936X036	M	36	M12	25	19	36	4	10	11	28	136	07113-25107

Order No.	Form	D1	D2	D3	H	H1	H2	T	Ball-Ø	Load rating max. kN (static load only)	Order No. stainless steel insert, diamond surface
02003-517X022	O	17	M6	10	22	4	10	7	13	28	07113-10105
02003-519X024	O	19	M8	12	24	4	10	8	15	39	07113-12105
02003-524X028	O	24	M10	16	28	4	10	8	20	58	07113-16105
02003-530X030	O	30	M12	20	30	4	10	9	23	95	07113-20105
02003-536X036	O	36	M12	25	36	4	10	11	28	136	07113-25105

Order No.	Form	D1	D2	D3	D4	H	H1	H2	T	Ball-Ø	Order No. stainless steel insert, polyurethane surface
02003-617X024	P	17	M6	10	10	24	6	12	7	13	07113-10126
02003-619X026	P	19	M8	12	13	26	6	12	8	15	07113-12126
02003-624X030	P	24	M10	16	16	30	6	12	8	20	07113-16126
02003-630X032	P	30	M12	20	21	32	6	12	9	23	07113-20126
02003-636X038	P	36	M12	25	27	38	6	12	11	28	07113-25126