

Item description/product images



Description

Material:

Carriage body zinc.

Plastic bearing material iglidur® J.

Rail anodised aluminium.

Version:

Body chromed.

Guide rail natural colour anodised.

Note:

Miniature slide guides are maintenance-free and corrosion resistant. Very high speeds and accelerations are possible due to the low weight. Applicable temperature max. 80 °C.

Miniature slide guides are insensitive to dust and are ideal for dry running.

** length L2 = 30 mm and

* L = 1000 mm included

L2 and L only available in full mm.

Drawings

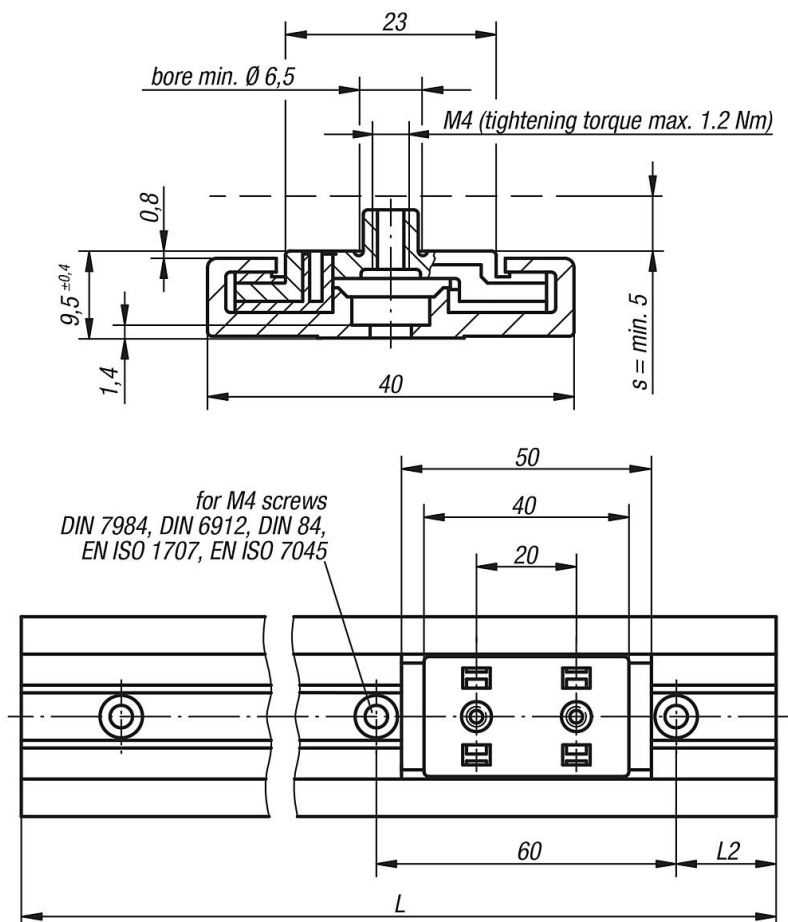

Drawings

static load capacity and geometrical moment of inertia

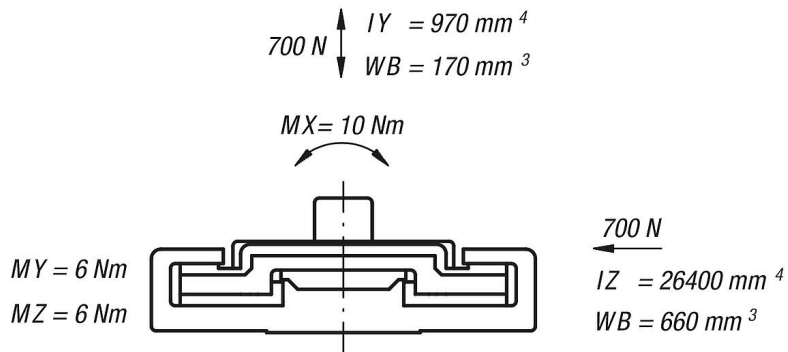

Overview of items

Carriage

Order No.	Version 2
21230-4000	-
21230-4010	floating bearing

Guide rails

Order No.	Version	L max.	L2
21230-4030X3000	-	3000	30

Order No.	Version	L2	L2 min.	L2 max.
21230-40**X*	-	**	20	49