

Item description/product images



Description

Material:

Housing thick steel plate.
Wheels high-quality PA 6.

Version:

Housing press formed.
Swivel castor housing with strong fork and base plate, very robust centre pin bolted and secured. The swivel head is additionally reinforced with specially formed and hardened bearing shells.

Note:

The hardened bearing shells make these castors particularly shock and impact proof. The wheels have high abrasion resistance. Wheel axle bolted.

Drawings

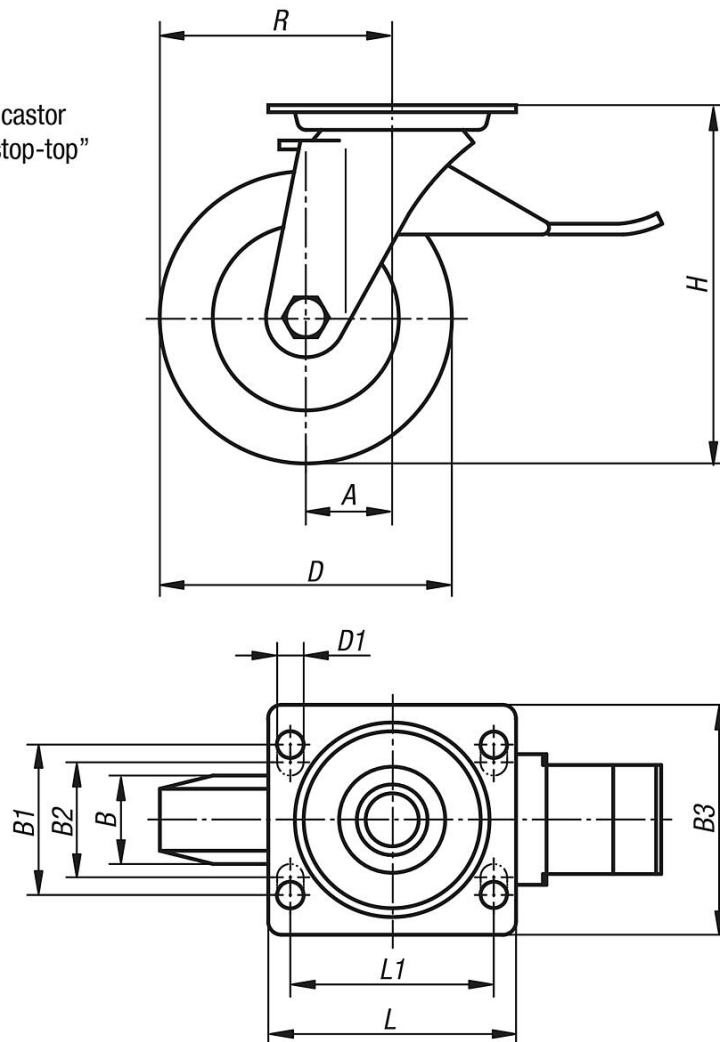
swivel castor
with "stop-top"

Drawings

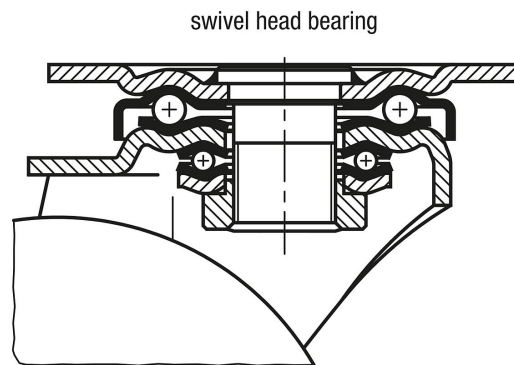

Overview of items

Order No.	Item	Version 1	Wheel bearing	A	B	B1	B2	B3	D	D1	H	L	L1	R	Permissible load kg
95040-075322	Swivel castor	with stop-top locking system	plain bearing	45	32	60	-	85	75	9	118	100	80	82,5	300
95040-075325	Swivel castor	with stop-top locking system	ball bearing	45	32	60	-	85	75	9	118	100	80	82,5	300
95040-100372	Swivel castor	with stop-top locking system	plain bearing	45	37	60	-	85	100	9	140	100	80	95	500
95040-100375	Swivel castor	with stop-top locking system	ball bearing	45	37	60	-	85	100	9	140	100	80	95	500
95040-125402	Swivel castor	with stop-top locking system	plain bearing	45	40	60	-	85	125	9	165	100	80	107,5	700
95040-125405	Swivel castor	with stop-top locking system	ball bearing	45	40	60	-	85	125	9	165	100	80	107,5	700
95040-150502	Swivel castor	with stop-top locking system	plain bearing	65	50	80	75	110	150	11	197	140	105	140	800
95040-150505	Swivel castor	with stop-top locking system	ball bearing	65	50	80	75	110	150	11	197	140	105	140	800