

Item description/product images



Description

Material:

Housing solid welded steel construction.

Wheels with welded steel body and Extrathane® tread.

Version:

The housing is a rugged welded steel construction.

Swivel castor housing with DIN 711 axial groove ball bearing and DIN 720 tapered roller bearing in the swivel head. Dust and splash-proof, with grease nipple.

Precision ball bearings in the wheels.

Note:

Centre pin welded in, bolted and secured. Wheel axle bolted.

Drawings

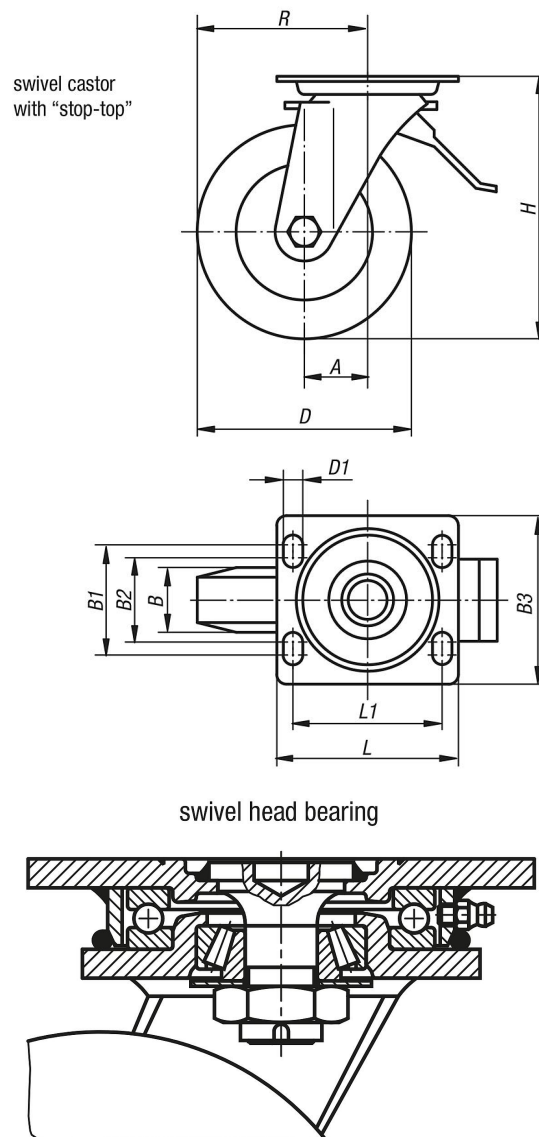

Overview of items

Order No.	Item	Version 1	Wheel bearing													Permissible load kg
				A	B	B1	B2	B3	D	D1	H	L	L1	R		
95032-160502	Swivel castor	with stop-top locking system	ball bearing	55	50	80	75	110	160	11	205	140	105	135	700	
95032-200502	Swivel castor	with stop-top locking system	ball bearing	60	50	80	75	110	200	11	245	140	105	160	1000	
95032-250602	Swivel castor	with stop-top locking system	ball bearing	75	60	105	-	140	250	14	305	175	140	200	1350	