

Item description/product images

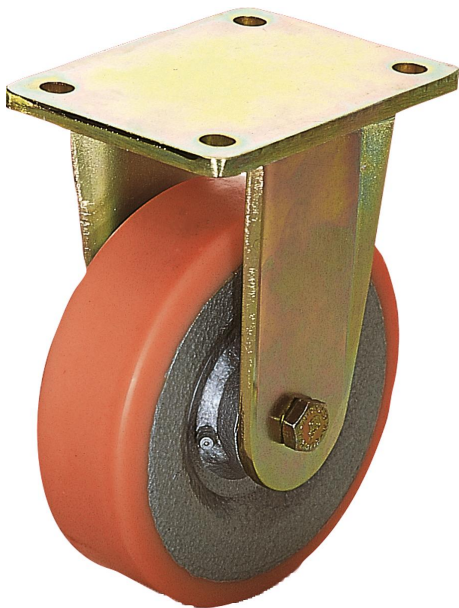

Description

Material:

Housing solid welded steel construction.

Wheels with welded steel body and Extrathane® tread.

Version:

The housing is a rugged welded steel construction; wheels with precision ball bearing

Note:

Centre pin welded in, bolted and secured. Wheel axle bolted.

Drawings

fixed castor

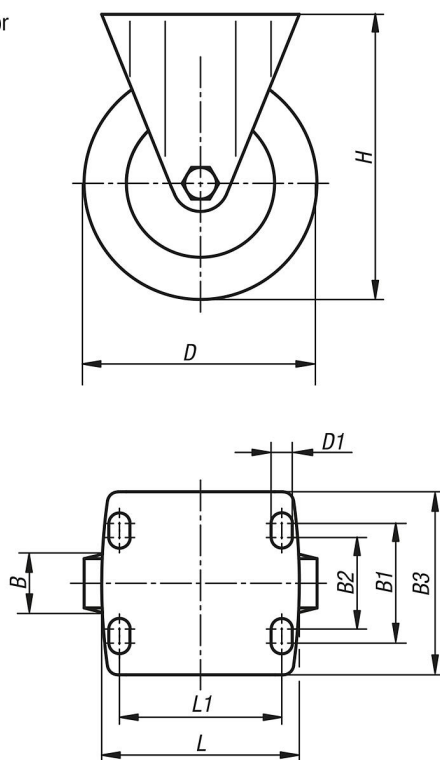

Overview of items

Order No.	Item	Version 1	Wheel bearing	B	B1	B2	B3	D	D1	H	L	L1	Permissible load kg
95032-160501	Fixed castor	without locking system	ball bearing	50	80	75	110	160	11	205	140	105	700
95032-200501	Fixed castor	without locking system	ball bearing	50	80	75	110	200	11	245	140	105	1000
95032-250601	Fixed castor	without locking system	ball bearing	60	105	-	140	250	14	305	175	140	1350

