

Assembly instructions

Before mounting the levelling foot, make sure that the angle of the floor is less than 8° (see Fig. 1). It should also be ensured that the surface on which the levelling foot is placed is free from cracks and gaps. If any cracks or gaps are present, they should be covered with a sealing agent (see Fig. 2).

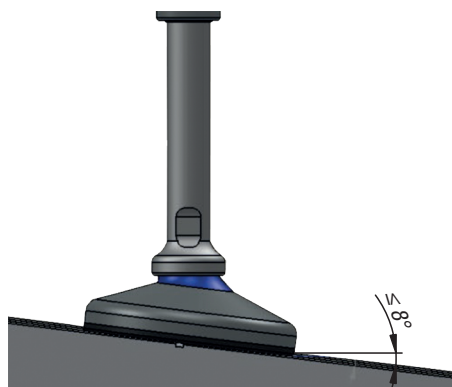

(Fig. 1)

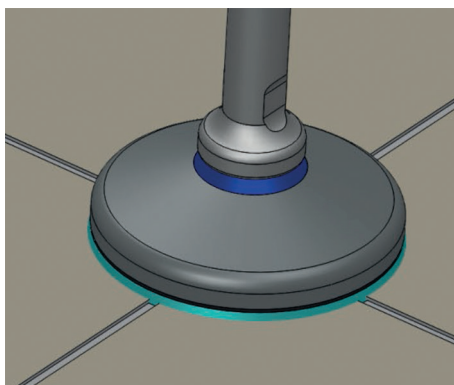

(Fig. 2)

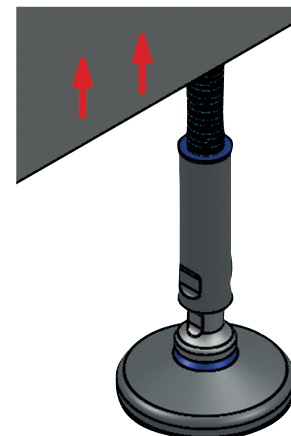

(Fig. 3)

Lift the machine to enable the levelling feet to be mounted easily. Make sure that the seal is positioned correctly on the sleeve and that the contact surface of the machine does not have any sharp edges or defects which could damage the seal on the sleeve.

Grease the threaded spindle and remove the excess grease. The sleeve should be mounted with the flat facing downwards (see Fig. 3).

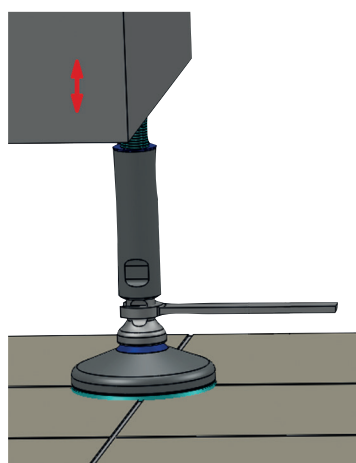

(Fig. 4)

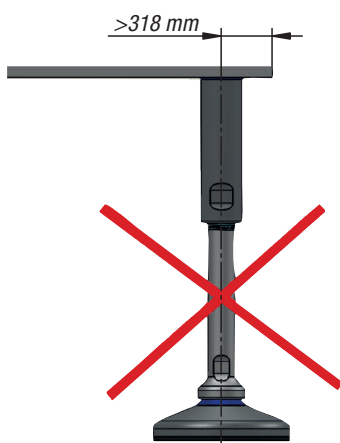

(Fig. 5)

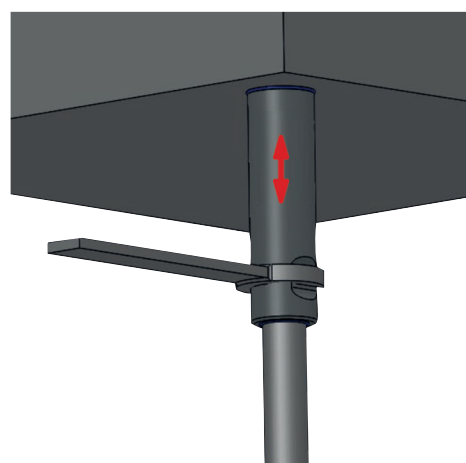

(Fig. 6)

Use a spanner to adjust the height as required (see Fig. 4).

Make sure that the bottom section of the sleeve covers the thread of the threaded spindle (see Fig. 5).

When you have achieved the required position, secure with the sleeve (see Fig. 6).

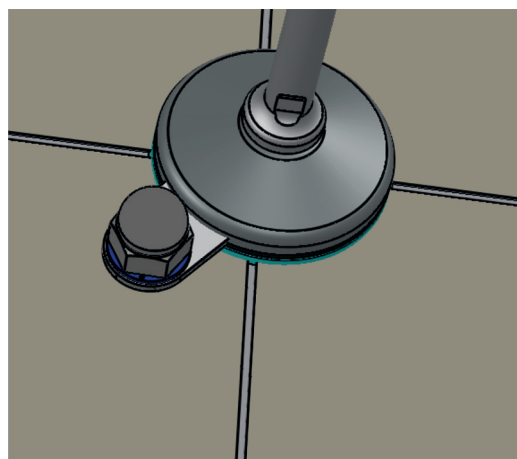

(Fig. 7)

To ensure optimum cleaning, a minimum height (from the ground to the machine) of 102 mm must/should be observed. However, if the distance from the outside edge of the machine to the fastening hole is greater than 318 mm (see Fig. 5), a minimum height of 152 mm must be observed.

If the levelling feet are secured to the ground, please use the matching accessories. Use a screw anchor or a dowel. Then attach the sealing washer and tighten the cap nut (see Fig. 7).