

Item description/product images

**Description****Material:**

Housing stainless steel 1.4301.
Wheel rim, high-quality thermoplastic polyurethane.
Wheel tread, high-quality polyamide.

Version:

Housing press formed.
Double ball bearing in the castor head.
Plain bearing in wheels.

Note:

Wheel axle bolted.
Swivel and fixed castors with mounting plate.

Application:

Loads can be transported with low noise and maximum ease in area's with high hygiene requirements.

Temperature range:

-20 °C - +70 °C.

Drawings

fixed castor

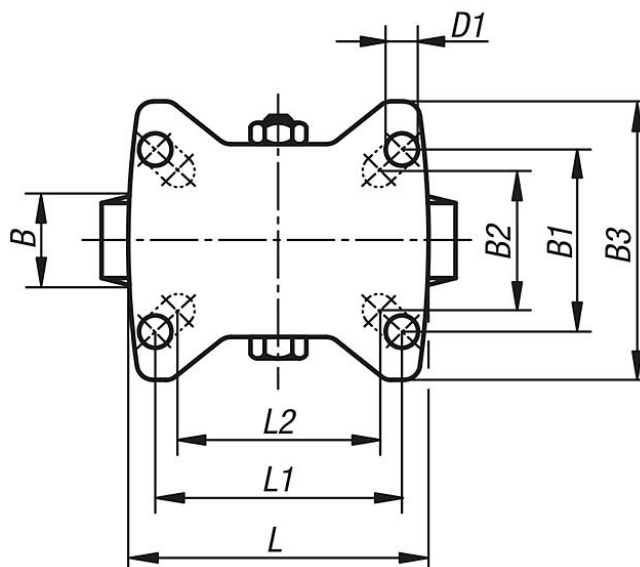
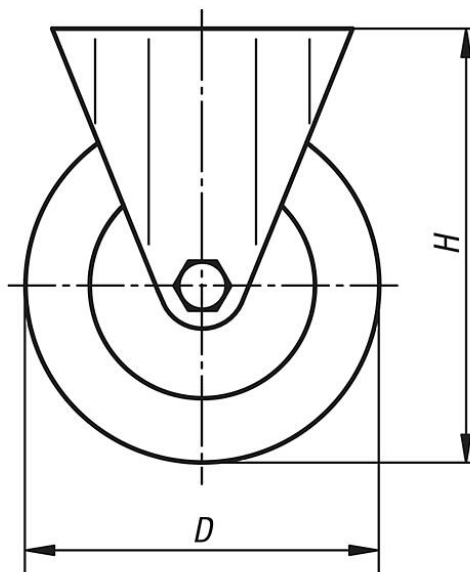

Overview of items

Order No.	Item	Wheel bearing	B	B1	B2	B3	D	D1	H	L	L1	L2	Permissible load kg
95046-01-211000351	Fixed castor	plain bearing	35	60	55	85	100	9	125	100	80	76	200
95046-01-211250401	Fixed castor	plain bearing	40	60	55	85	125	9	150	100	80	76	250
95046-01-211600451	Fixed castor	plain bearing	45	80	75	110	160	11	195	140	105	-	400
95046-01-212000501	Fixed castor	plain bearing	50	80	75	110	200	11	235	140	105	-	400