



Description

Material:
Steel housing.
Nitrile rubber seal.

Version:
Ground edges.

Technical data:
All bearings are supplied ready for mounting with lubricating grease type KE2P-35 acc. to DIN 51825.

Housing and shaft tolerances correspond to roundness tolerance class IT2 and perpendicularity tolerance class IT4.

Application:
For thread drive bearing.

Temperature range:
-30 °C to +120 °C.

Assembly:
Precision slotted nuts must be used for mounting the threaded spindles.

To compensate for any material settling during assembly, tighten the slotted nuts using 2x tightening torque, loosen slightly and then tighten using the prescribed tightening torque.

Tighten fastening screws crosswise up to max. 70% of the yield point.

Drawings

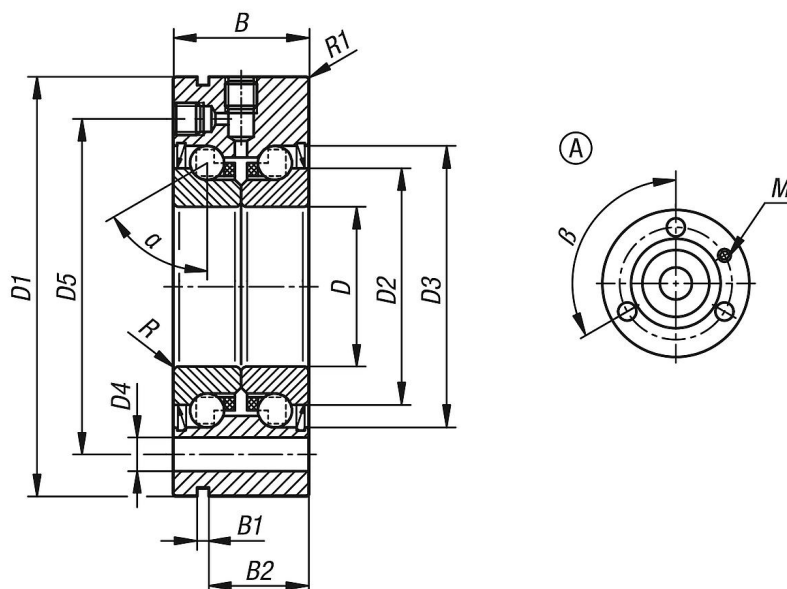

23806-01_A Axial angular contact ball bearing, steel, double row with flange, Form A



Overview of items

Order No.	Abbreviation	Version 1	Form	B	B1	B2	D	D1	D2	D3	D4	D5	R	R1	α	β	M	Tightening torque, precision locknut Nm	Speed limit rpm
23806-01-101205525	1255-2RS	double-row	A	25 -0,25	3	17	12-0,005	55-0,01	25	-	6,6	42	0,3	0,6	60°	120°	M6	8	3800

Order No.	Abbreviation	Static load rating N	Dynamic load rating N	Axial rigidity N/ μ m	Tilt rigidity Nm/mrad	Bearing friction torque Nm	Moment of inertia kg.cm ²	Circular runout μ m	Radial bearing clearance	Hole tolerance μ m	OD tolerance μ m	Width tolerance μ m
23806-01-101205525	1255-2RS	24700	16900	375	50	0,16	0,068	2,0	pre-tensioned	0-5	0-10	0-250