

Item description/product images

**Description****Material:**

Washer steel 1.0715.

Wedges steel 1.0715 or stainless steel 1.4305.

Version:

Washer electro zinc-plated.

Wedges black oxidised or blank.

Note:

For fixating adapter plates, angles and plates open on grid hole tables or plates with $\varnothing 16$ mm, $\varnothing 20$ mm or $\varnothing 28$ mm holes. Can also be used as a point end stop for positioning and fixating exchange clamping plates. By turning the cap screw, the lock wedges expand in the bore.

Advantages:

Functions also in thin table material (metal: ≥ 8 mm or ≥ 4 mm ; wood ≥ 18 mm).

Gentle clamping in the bore.

Low height.

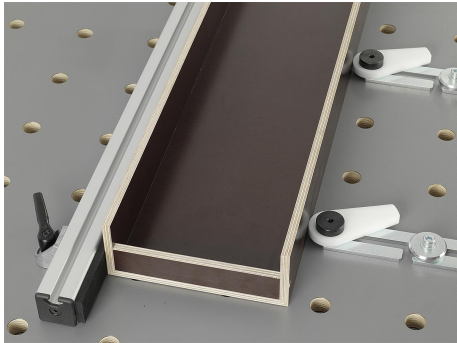

Drawings

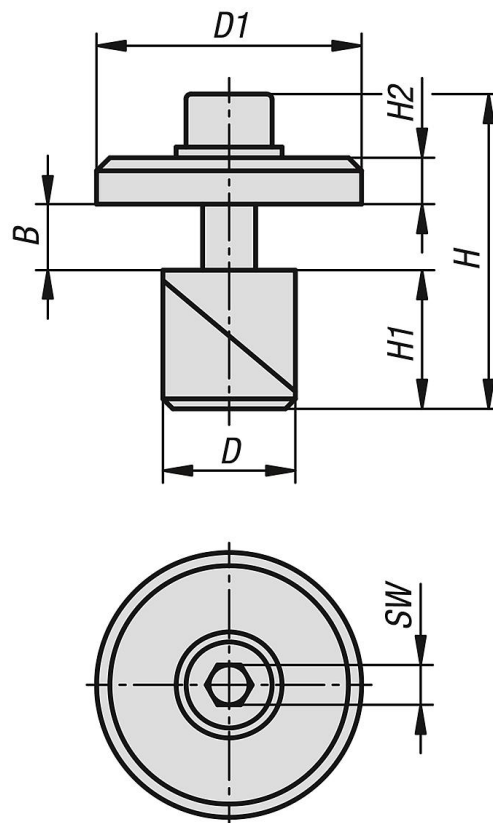

Overview of items

Order No.	Main material	D	D1	H	H1	H2	SW	B Clamp range
04754-016	steel	16	40	48	17,5	7	6	0-14
04754-120	stainless steel	20	40	48	21	7	6	0-10
04754-028	steel	28	40	68	28	7	6	0-23