

Item description/product images



Description

Material:

Housing steel plate.
Wheels with thermoplastic rubber tread.
Wheel body polypropylene.

Version:

Housing press formed.
Double ball bearing in the castor head.
Plain bearing in wheels.

Note:

Wheel axle threaded. Swivel castors with bolt hole. Electrically conductive wheels, non-marking grey. The ohmic resistance of the wheel $\leq 10^4 \Omega$.

Application:

Electrically conductive wheels on swivel and fixed castors are used to protect against electrostatic discharge generated by transport equipment or the transported goods. Damage to sensitive goods and painful electrostatic shocks to the personal is so prevented.

Temperature range:

-20 °C to +60 °C.

Drawings

swivel castor with "stop-fix"

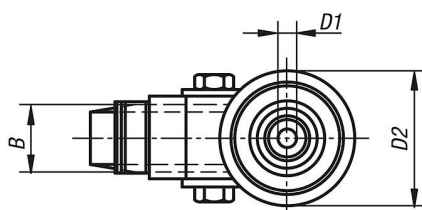
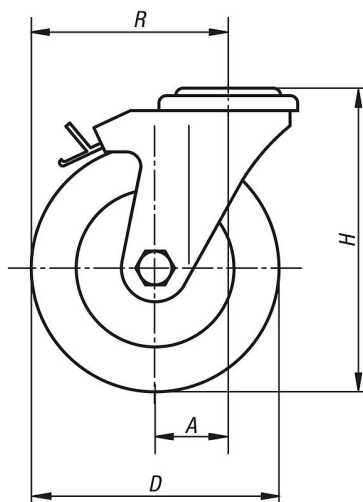

swivel head bearing

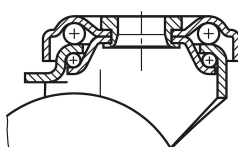

Overview of items

Order No.	Item	Version 1	Wheel bearing	A	B	D	D1	D2	H	R	Permissible load kg
95010-11050192	Swivel castor	with stop-fix locking system	plain bearing	25	19	50	11	43	69	50	30
95010-11075252	Swivel castor	with stop-fix locking system	plain bearing	29	25	75	11	43	98	66,5	50
95010-11100252	Swivel castor	with stop-fix locking system	plain bearing	33	25	100	11	43	121	83	60